

Amateur Radio

Technician Class License

Study Guide

(For use July 1, 2010 to June 30, 2014)

Compliments of:

Earl

N8KBR

Source Material is Publicly Available

Question Pool of 396 questions released 4 Jan 2010, as revised,

and CFR Title 47, Part 97, Amateur Radio Service.

This document may be freely distributed and was developed for not-for-profit use only.

Foreword

This document is simply a compilation of the publicly available question pool which has been converted into statements and formatted. The intent was to retain as much of the original words from the question pool as possible to leverage familiarization in the learning and memory process. Specific references to Part 97 are retained throughout. The 15 terms most frequently used in the text are:

amateur	control	operator
antenna	current	power
band	electrical	radio
circuit	FCC	signals
communication	frequency	station

The author's hope is that this document might be useful as a resource in studying for the Element 2, Technician Class License Amateur Radio Exam.

Table of Contents

<u>ELEMENT 2 SUBELEMENT</u>	<u>Page #</u>
T1 - FCC Rules	3
T2 - Operating Procedures	7
T3 - Radio wave characteristics	9
T4 - Amateur radio practices and station set up	11
T5 - Electrical principles	12
T6 - Electrical components	15
T7 - Station equipment	17
T8 - Modulation modes	21
T9 - Antennas, feedlines	23
T0 - AC power circuits, antenna installation, RF hazards	24

SUBELEMENT T1 - FCC Rules, descriptions and definitions for the amateur radio service, operator and station license responsibilities [6 Exam Questions - 6 Groups]

T1A - Amateur Radio services

Purpose of the amateur service, Operator/primary station license grant

- The Amateur Radio Service is intended for those persons who are interested in radio technique solely with a personal aim and without pecuniary interest. [97.3(a)(4)]
- An amateur station is a station in an Amateur Radio Service consisting of the apparatus necessary for carrying on radio communications. [97.3(a)(5)]
- An Auxiliary station transmits signals over the air from a remote receive site to a repeater for retransmission. [97.3(a)(7)]
- Amateur operators in a local or regional area whose stations are eligible to be auxiliary or repeater stations select a Frequency Coordinator. [97.3(a)(22)]
- A Frequency Coordinator recommends transmit/receive channels and other parameters for auxiliary and repeater Stations. [97.3(a)(22)]
- Harmful interference is defined as that which seriously degrades, obstructs, or repeatedly interrupts a radio communication service operating in accordance with the Radio Regulations. [97.3(a)(23)]

Amateur-satellite service

- A space station is an amateur station located more than 50 km above the Earth's surface. [97.3(a)(40)]
- Telecommand is a one-way transmission to initiate, modify or terminate functions of a device at a distance. [97.3(a)(43)]
- Telemetry is a one-way transmission of measurements at a distance from the measuring instrument. [97.3(a)(45)]

Where FCC rules are codified, Basis and purpose of FCC rules, Meanings of basic terms used in FCC rules

- The Federal Communications Commission (FCC) is the government agency that regulates and enforces the rules for the Amateur Radio Service in the United States. [97.1]
- Part 97 of the FCC rules contains the rules and regulations governing the Amateur Radio Service.

T1B - Authorized frequencies

Frequency allocations [97.301(a)]

- The frequency, 52.525 MHz, is within the 6 meter band.
- You are using the 2 meter amateur band when your station is transmitting on 146.52 MHz.
- You are the 1.25 meter amateur band if you are transmitting on 223.50 MHz.
- The 70 cm frequency, 443.350 MHz, is authorized to a Technician Class license holder operating in ITU Region 2.
- The 23 cm frequency, 1296 MHz, is authorized to a Technician Class operator license.

ITU regions

- The International Telecommunication Union (ITU) is a United Nations agency for information and communication technology issues. [97.3(a)(28)]
- North American amateur stations are located in ITU Region 2.

Emission type

- The only emission mode, CW, is permitted in the mode-restricted sub-bands at 50.0 to 50.1 MHz and 144.0 to 144.1 MHz. [97.305 (a)(c)]

Restricted sub-bands

- The 6 meter, 2 meter, and 1.25 meter bands, available to Technician Class operators, have mode-restricted sub-bands. [97.305(c)]

Spectrum sharing

- According to the FCC rules, when an amateur frequency band is said to be available on a secondary basis, amateurs may not cause harmful interference to primary users. [97.303]

Transmissions near band edges

- You should not set your transmit frequency to be exactly at the edge of an amateur band or sub-band for ALL of the following reasons [97.101(a)]:
 - To allow for calibration error in the transmitter frequency display
 - So that modulation sidebands do not extend beyond the band edge
 - To allow for transmitter frequency drift

T1C - Operator classes and station call signs

Sequential, special event, and vanity call sign systems

- A special event call sign has a single letter in both the prefix and suffix. [97.3(a)(11)(iii)]
- W3ABC would be an example of a valid US amateur radio station call sign.

Station license and licensee

- You may operate a transmitter on an amateur service frequency after you pass the examination required for your first amateur radio license and as soon as your name and call sign appear in the FCC's Universal Licensing System (ULS) database. [97.5a]

International communications

- International communications permitted by an FCC-licensed amateur station are communications incidental to the purposes of the amateur service and remarks of a personal character. [97.117]
- If you are operating on the 23 cm band and learn that you are interfering with a radiolocation station outside the United States, you must stop operating or take steps to eliminate the harmful interference. [97.303(h)]

Reciprocal operation

- You are allowed to operate your amateur station in a foreign country when the foreign country authorizes it.

Places where the amateur service is regulated by the FCC

- An FCC-licensed amateur station may transmit from any vessel or craft located in international waters and documented or registered in the United States, in addition to places where the FCC regulates communications. [97.5(a)(2)]

Name and address on ULS

- When correspondence from the FCC is returned as undeliverable because the grantee failed to provide the correct mailing address revocation of the station license or suspension of the operator license may be the result. [97.23]

License term, renewal, and grace period

- Ten years is the normal term for an FCC-issued primary station/operator license grant. [97.25]
- If your license has expired and is still within the allowable grace period, you may NOT continue to operate a transmitter on amateur service frequencies until the ULS database shows that the license has been renewed. [97.21(b)]
- There is a grace period of two years following the expiration of an amateur license within which the license may be renewed. [97.21(a)(b)]

T1D - Authorized and prohibited transmissions

- FCC-licensed amateur stations are prohibited from exchanging communications with any country whose administration has notified the ITU that it objects to such communications. [97.111(a)(1)]
- During an Armed Forces Day Communications Test an FCC-licensed amateur station may exchange messages with a U.S. military station. [97.111(a)(5)]
- The transmission of codes or ciphers are allowed to hide the meaning of a message transmitted by an amateur station only when transmitting control commands to space stations or radio control craft. [97.113(a)(4), 97.211(b), 97.217]
- The only time an amateur station is authorized to transmit music is when incidental to an authorized retransmission of manned spacecraft communications. [97.113(a)(4), 97.113(e)]
- Amateur radio operators may use their stations to notify other amateurs of the availability of equipment for sale or trade when the equipment is normally used in an amateur station and such activity is not conducted on a regular basis. [97.113(a)(3)]
- Transmissions that contain obscene or indecent words or Language are prohibited. [97.113(a)(4)]
- An amateur station is authorized to automatically retransmit the radio signals of other amateur stations when the signals are from an auxiliary, repeater, or space station. [97.113(f)]
- The control operator of an amateur station may receive compensation for operating the station when the communication is incidental to classroom instruction at an educational institution. [97.113]
- Assuming no other means is available, amateur stations are authorized to transmit signals related to broadcasting, program production, or news gathering, only where such communications directly relate to the immediate safety of human life or protection of property. [97.113(b)]
- In the FCC rules for the amateur services, the term broadcasting means transmissions intended for reception by the general public. [97.3(a)(10)]
- Brief transmissions to make station adjustments are permitted in the Amateur Radio Service. [97.113(a)(5)]

T1E - Control operator and control types

Control operator required

- An amateur station must have a control operator when the station is transmitting. [97.7(a)]

Control point, location of control operator

- The amateur station control point is the location at which the control operator function is performed. [97.3(a)(14)]

Designation of control operator

- The station licensee must designate the station control operator. [97.103(b)]
- The FCC presumes the station licensee to be the control operator of an amateur station, unless documentation to the contrary is in the station records. [97.103(a)]

- When the control operator is not the station licensee, the control operator and the station licensee are equally responsible for the proper operation of the station. [97.103(a)]

Local, automatic and remote control

- For the type of control, called Automatic control, it is permissible for the control operator to be at a location other than the control point. [97.109(d)]
- When the control operator is not present at a control point for a repeater, automatic control is being used. [97.3(a)]
- Local control is being used when transmitting using a handheld radio. [97.109(a)]
- Remote control is used when the control operator is not at the station location but can indirectly manipulate the operating adjustments of a station. [97.3]

Eligibility

- Only a person for whom an amateur operator/primary station license grant appears in the FCC database or who is authorized for alien reciprocal operation is eligible to be the control operator of an amateur station. [97.7(a)]

Privileges and duties

- The class of operator license held by the control operator determines the transmitting privileges of an amateur station. [97.103(b)]

T1F - Station identification and operation standards

Station identification

- When identifying a station on the air as "Race Headquarters" a Tactical call is the type of identification being used.
- When using tactical identifiers, your station must transmit the station's FCC-assigned call sign every ten minutes. [97.119 (a)]
- An amateur station is required to transmit its assigned call sign at least every 10 minutes during and at the end of a contact. [97.119(a)]
- The English language is an acceptable language for use for station identification when operating in a phone sub-band. [97.119(b)]
- The method of call sign identification required for a station transmitting phone signals is sending the call sign using CW or phone emission. [97.119(b)]
- ALL of the following formats of a self-assigned indicators are acceptable when identifying using a phone transmission [97.119(c)]:
 - KL7CC stroke W3
 - KL7CC slant W3
 - KL7CC slash W3
- When appending a self-assigned call sign indicator it must not conflict with any other indicator specified by the FCC rules or with any call sign prefix assigned to another country. [97.119(c)]
- A Technician Class licensee may never be the control operator of a station operating in an exclusive Extra Class operator segment of the amateur bands. [97.119(e)]

Special operations for repeaters and auxiliary stations, station security

- A Repeater station simultaneously retransmits the signal of another amateur station on a different channel or channels. [97.3(a)(39)]
- The control operator of the originating station is accountable should a repeater inadvertently retransmit communications that violate the FCC rules. [97.205(g)]

Third party communications

- The FCC rules authorizes the transmission of non-emergency third party communications to any foreign station whose government permits such communications. [97.115(a)]

Club stations

- At least 4 people are required to be members of a club for a club station license to be issued by the FCC. [97.5(b)(2)]

FCC inspection

- The station licensee must make the station and its records available for FCC inspection any time upon request by an FCC representative. [97.103(c)]

SUBELEMENT T2 - Operating Procedures - [3 Exam Questions – 3 Groups]

T2A - Station operation

Choosing an operating frequency, frequency use

- The most common repeater frequency offset in the 2 meter band is plus or minus 600 kHz.
- A common repeater frequency offset in the 70 cm band is plus or minus 5 MHz.
- The national calling frequency for FM simplex operations in the 70 cm band is 446.000 MHz.

Calling another station

- An appropriate way to call another station on a repeater, if you know the other station's call sign, is to say the station's call sign then identify with your call sign.
- When responding to a call of CQ, you should transmit the other station's call sign followed by your call sign.
- The meaning of the procedural signal "CQ" is calling any station.
- A brief statement often used in place of "CQ" to indicate that you are listening on a repeater is to say your call sign.

Test transmissions

- An amateur operator must properly identify the transmitting station when making on-air transmissions to test equipment or antennas.
- When making a test transmission station identification is required at least every ten minutes during the test and at the end.

Use of minimum power

- The FCC rules regarding power levels used in the amateur bands require an amateur to use the minimum transmitter power necessary to carry out the desired communication. [97.313(a)]

Band plans

- A band plan is a voluntary guideline for using different modes or activities within an amateur band supplementing, but not replacing, those established by the FCC.

T2B - VHF/UHF operating practices

SSB phone

- If you receive a report that your station's transmissions are causing splatter or interference on nearby frequencies you should check your transmitter for off-frequency operation or spurious emissions.
- If your station's transmission unintentionally interferes with another station the proper course of action is properly identify your transmission and move to a different frequency.

Simplex

- Simplex communication is the term used to describe an amateur station that is transmitting and receiving on the same frequency.
- The amplitude of the modulating signal determines the amount of deviation of an FM signal.
- When the deviation of an FM transmitter is increased it's signal occupies more bandwidth.

FM repeater, frequency offsets, splits and shifts

- ALL of the following common problems might cause you to be able to hear but not access a repeater even when transmitting with the proper offset:
 - The repeater receiver requires audio tone burst for access
 - The repeater receiver requires a CTCSS tone for access
 - The repeater receiver may require a DCS tone sequence for access

CTCSS, DTMF, Tone Squelch

- Continuous Tone Coded Squelch System (**CTCSS**) is the term used to describe the use of a sub-audible tone transmitted with normal voice audio to open the squelch of a receiver.

Carrier Squelch

- Carrier squelch is the muting of receiver audio controlled solely by the presence or absence of an RF signal.

"Q" Signals

- The "Q" signal, QRM, is used to indicate that you are receiving interference from other stations.
- The "Q" signal, QSY, is used to indicate that you are changing frequency.

Phonetics

- Use of a phonetic alphabet is encouraged by the FCC when identifying your station when using phone.

T2C - Public service

Emergency and non-emergency operations

- The FCC Rules apply to proper operation of your station when using amateur radio at the request of public service officials. [97.103(a)]
- The government agency sponsoring the event must submit the request for a temporary waiver of Part 97.113 to allow amateur radio operators to provide communications on behalf of their employers during a government sponsored disaster drill. [97.113 and FCC Public Notice DA 09-2259]
- It is legal for an amateur licensee to provide communications on behalf of their employer during a government sponsored disaster drill or exercise only when the FCC has granted a government-requested waiver. [97.113]
- RACES and ARES are common in that both organizations may provide communications during emergencies.

- The Radio Amateur Civil Emergency Service is a radio service using amateur stations for emergency management or civil defense communications. [97.3(a)(37), 97.407]
- When normal communications systems are not available an amateur station may use any means of radio communications at its disposal for essential communications in connection with immediate safety of human life and protection of property. [97.403]

Message traffic handling

- A common practice during net operations to get the immediate attention of the net control station when reporting an emergency is to begin your transmission with "Priority" or "Emergency" followed by your call sign.
- To minimize disruptions to an emergency traffic net, once you have checked in, do not transmit on the net frequency until asked to do so by the net control station.
- Passing messages exactly as written, spoken or as received is usually considered to be the most important job of an amateur operator when handling emergency traffic messages.
- The preamble in a formal traffic message is the information needed to track the message as it passes through the amateur radio traffic handling system.
- The term, "check", is a count of the number of words or word equivalents in the text portion of the formal traffic message.

SUBELEMENT T3 - Radio wave characteristics, radio and electromagnetic properties, propagation modes - [3 Exam Questions - 3 Groups]

T3A - Radio wave characteristics

How a radio signal travels

- An Electromagnetic wave carries radio signals between transmitting and receiving stations.
- A common effect of "skip" reflections between the Earth and the ionosphere is the polarization of the original signal is randomized.
- The part of the atmosphere called the ionosphere enables the propagation of radio signals around the world.
- **Fading, multipath**
- If The term, Picket fencing, is commonly used to describe the rapid fluttering sound sometimes heard from mobile stations that are moving while transmitting.
- Another operator reports that your station's 2 meter signals were strong just a moment ago, but now they are weak or distorted try moving a few feet, as random reflections may be causing multi-path distortion.
- Error rates are likely to increase if VHF or UHF data signals propagate over multiple paths.
- Random combining of signals arriving via different path lengths is the cause of irregular fading of signals from distant stations during times of generally good reception is Random combining of signals arriving via different path lengths.

Wavelength vs. penetration

- UHF signals are often more effective from inside buildings than VHF signals due to the shorter wavelength allowing them to more easily penetrate the structure of buildings.

Antenna orientation

- Horizontal antenna polarization is normally used for long-distance weak-signal CW and SSB contacts using the VHF and UHF bands.

- Signals could be significantly weaker if the antennas at opposite ends of a VHF or UHF line of sight radio link are not using the same polarization.
- If buildings or obstructions are blocking the direct line of sight path when using a directional antenna, try to find a path that reflects signals to the repeater to access a distant repeater.

T3B - Radio and electromagnetic wave properties

The electromagnetic spectrum

- Frequency range is referred to as HF for 3 to 30 MHz.
- Frequency limits of the VHF spectrum are 30 to 300 MHz.
- Frequency limits of the UHF spectrum are 300 to 3000 MHz.

Wavelength vs. frequency

- Wavelength is the name for the distance a radio wave travels during one complete cycle.
- Frequency is the term describing the number of times per second that an alternating current reverses direction.
- There is an inverse relationship between wavelength of a radio wave and its frequency. The wavelength gets shorter as the frequency increases.
- The formula for converting frequency to wavelength in meters is wavelength in meters equals 300 divided by frequency in megahertz.
- The approximate wavelength property of radio waves is often used to identify the different frequency bands, e.g., 2 meters for 144 to 148 MHz band.

Velocity of electromagnetic waves

- A radio wave travels through free space at the speed of light.
- The approximate velocity of a radio wave as it travels through free space is 300,000,000 meters per second.

Electromagnetic wave properties

- The two components of a radio wave are electric and magnetic fields.

T3C - Propagation modes, F layer skip

Line of sight

- Direct UHF signals (not via a repeater) are rarely heard from stations outside your local coverage area because UHF signals are usually not reflected by the ionosphere.
- VHF and UHF radio signals usually travel somewhat farther than the visual line of sight distance between two stations because the Earth seems less curved to radio waves than to light.

Meteor scatter

- The 6 meter band is best suited to communicating via meteor scatter.

Aurora scatter/reflection

- Signals exhibiting rapid fluctuations of strength and often sounding distorted is a characteristic of VHF signals received via auroral reflection

Tropospheric ducting/scatter

- Tropospheric ducting is caused by temperature inversions in the atmosphere.
- Tropospheric scatter mode is responsible for allowing over-the-horizon VHF and UHF communications to ranges of approximately 300 miles on a regular basis.

Sporadic E

- When VHF signals are being received from long distances signals are possibly being refracted from a sporadic E layer in the atmosphere.
- The Sporadic E propagation type is most commonly associated with occasional strong over-the-horizon signals on the 10, 6, and 2 meter bands.

Radio horizon

- The radio horizon is the distance at which radio signals between two points are effectively blocked by the curvature of the Earth.
- The term "knife-edge" propagation refers to signals that are partially refracted around solid objects exhibiting sharp edges.
- Generally, the best time for long-distance 10 meter band propagation is during daylight hours.

SUBELEMENT T4 - Amateur radio practices and station set up – [2 Exam Questions - 2 Groups]

T4A - Station setup

Microphone

- Some connectors on amateur transceivers include push-to-talk and voltages for powering the microphone.

Speaker, Headphones

- A set of headphones could be used in place of a regular speaker to help you copy signals in a noisy area.

Filters

- To reduce harmonic emissions, a filter would need to be installed between the transmitter and the antenna.
- A Band-reject filter should be connected to a TV receiver as the first step in trying to prevent RF overload from a nearby 2 meter transmitter.
- A Ferrite choke could be used to reduce RF current flowing on the shield of an audio cable.

Power source

- A good reason to use a regulated power supply for communications equipment is it prevents voltage fluctuations from reaching sensitive circuits.
- The alternator is the source of a high-pitched whine that varies with engine speed in a mobile transceiver's receive audio.
- A mobile transceiver's power negative connection should be made at the battery or engine block ground strap.

Connecting a computer

- A Terminal node controller would be connected between a transceiver and computer in a packet radio station.

- When conducting digital communications, the computer's sound card provides audio to the microphone input and converts received audio to digital form.

RF grounding

- A Flat strap type of conductor is best to use for RF grounding.

T4B - Operating controls

Microphone Gain

- If a transmitter is operated with the microphone gain set too high the output signal might become distorted.

Tuning

- The keypad or VFO knob can be used to enter the operating frequency on a modern transceiver.
- The acronym for Receiver Incremental Tuning is "RIT".
- The receiver RIT or clarifier controls could be used if the voice pitch of a single-sideband signal seems too high or low.

Use of filters

- Turn on the noise blanker to reduce ignition interference to a receiver.
- The advantage of having multiple receive bandwidth choices on a *multimode transceiver is that permits noise or interference reduction* by selecting a bandwidth matching the mode.
- An appropriate receive filter to select in order to minimize noise and interference for SSB reception is 2400 Hz.
- An appropriate receive filter to select in order to minimize noise and interference for CW reception is 500 Hz.

Squelch, AGC

- The purpose of the squelch control on a transceiver is to mute receiver output noise when no signal is being received.

Repeater offset

- The common meaning of the term "repeater offset" is the difference between the repeater's transmit and receive frequencies.

Memory channels

- A way to enable quick access to a favorite frequency on your transceiver is to store the frequency in a memory channel.

SUBELEMENT T5 - Electrical principles, math for electronics, electronic principles, Ohm's Law - [4 Exam Questions - 4 Groups]

T5A - Electrical principles

Conductors and insulators

- Copper is a good electrical conductor.
- Glass is a good electrical insulator.

Power

- Electrical power is measured in units of Watts.
- The term, Power, describes the rate at which electrical energy is used.

Voltage

- Voltage is the electrical term for the electromotive force (EMF) that causes electron flow.
- A mobile transceiver usually requires about 12 volts (DC).
- The volt is the basic unit of electromotive force.

Current

- Electrical current is measured in units of Amperes.
- Current is the name for the flow of electrons in an electric circuit.

Alternating and direct current

- Direct current is the name for a current that flows only in one direction.
- Alternating current is the name for a current that reverses direction on a regular basis.

T5B - Math for electronics

Decibels

- The approximate amount of change, measured in decibels (dB), of a power increase from 5 watts to 10 watts is 3 dB.
- The approximate amount of change, measured in decibels (dB), of a power decrease from 12 watts to 3 watts is 6 dB.
- The approximate amount of change, measured in decibels (dB), of a power increase from 20 watts to 200 watts is 10 dB.

Electrical units and the metric system

- 1,500 milliamperes equals 1.5 amperes.
- Another way to specify a radio signal frequency of 1,500,000 hertz is 1500 kHz.
- One thousand volts are equal to one kilovolt.
- One one-millionth of a volt is equal to one microvolt.
- 0.5 watts is equivalent to 500 milliwatts.
- If an ammeter calibrated in amperes is used to measure a 3000-milliampere current, the reading that it would show is 3 amperes.
- If a frequency readout calibrated in megahertz shows a reading of 3.525 MHz, the readout would show 3525 kHz if it were calibrated in kilohertz.
- 1,000,000 picofarads is equal to 1 microfarad.

T5C - Electronic principles, Current flow in circuits, Alternating current

Capacitance

- Capacitance is the ability to store energy in an electric field.
- The farad is the basic unit of capacitance.

Inductance

- Inductance is the ability to store energy in a magnetic field.
- The Henry is the basic unit of inductance.

Definition of RF, Frequency

- The abbreviation, RF, refers to radio frequency signals of all types.
- A usual name for electromagnetic waves that travel through space is Radio waves.
- The unit of frequency is Hertz.

T5D - Ohm's Law

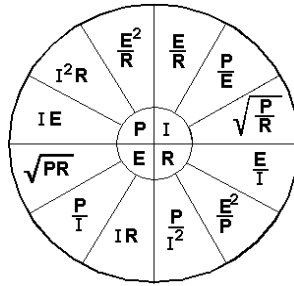
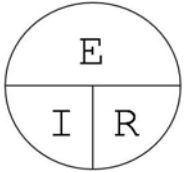

- **Resistance (R) equals voltage (E) divided by current (I) or $R=E/I$**
 - What is the resistance of a circuit in which a current of 3 amperes flows through a resistor connected to 90 volts? (Answer: 30 ohms)
 - What is the resistance in a circuit for which the applied voltage is 12 volts and the current flow is 1.5 amperes? (Answer: 8 ohms)
 - What is the resistance of a circuit that draws 4 amperes from a 12-volt source? (Answer: 3 ohms)
- **Current (I) equals voltage (E) divided by resistance (R) or $I=E/R$**
 - What is the current flow in a circuit with an applied voltage of 120 volts and a resistance of 80 ohms? (Answer: 1.5 amperes)
 - What is the current flowing through a 100-ohm resistor connected across 200 volts? (Answer: 2 amperes)
 - What is the current flowing through a 24-ohm resistor connected across 240 volts? (Answer: 10 amperes)
- **Voltage (E) equals current (I) multiplied by resistance (R) or $E=I*R$**
 - What is the voltage across a 2-ohm resistor if a current of 0.5 amperes flows through it? (Answer: 1 volt)
 - What is the voltage across a 10-ohm resistor if a current of 1 ampere flows through it? (Answer: 10 volts)
 - What is the voltage across a 10-ohm resistor if a current of 2 amperes flows through it? (Answer: 20 volts)

Power calculations



- The formula used to calculate electrical power in a DC circuit is: Power (P) equals voltage (E) multiplied by current (I) or $P=I*E$
 - How much power is being used in a circuit when the applied voltage is 13.8 volts DC and the current is 10 amperes? (Answer: 138 watts)
 - How much power is being used in a circuit when the applied voltage is 12 volts DC and the current is 2.5 amperes? (Answer: 30 watts)

- How many amperes are flowing in a circuit when the applied voltage is 12 volts DC and the load is 120 watts? (Answer: 10 amperes)

SUBELEMENT T6 - Electrical components, semiconductors, circuit diagrams, component functions - [4 Exam Questions - 4 Groups]

T6A - Electrical components

Fixed and variable resistors

- The Resistor is the electrical component used to oppose the flow of current in a DC circuit.
- A Potentiometer is a component often used as an adjustable volume control.
- Resistance is the electrical parameter is controlled by a potentiometer.

Capacitors

- A Capacitor is an electrical component that stores energy in an electric field.
- A Capacitor consists of two or more conductive surfaces separated by an insulator.

Inductors

- An Inductor is a type of electrical component that stores energy in a magnetic field.
- An Inductor is usually composed of a coil of wire.

Fuses

- A fuse is an electrical component used to protect other circuit components from current overloads.

Switches

- A Switch is an electrical component used to connect or disconnect electrical circuits.

Batteries

- The nominal voltage of a fully charged nickel-cadmium battery cell is 1.2 volts.
- A battery type that is not rechargeable is Carbon-zinc.

T6B – Semiconductors

Basic principles of diodes

- A Diode allows current to flow in only one direction.
- The names of the two electrodes of a diode are anode and cathode.
- A semiconductor diode's cathode lead is usually identified with a stripe.
- The abbreviation "LED" stands for Light Emitting Diode.

Basic principles of transistors

- Transistors are a class of electronic components capable of using a voltage or current signal to control current flow.
- A Transistor can be used as an electronic switch or amplifier.
- Transistors can amplify signals.
- Gain is the term that describes a transistor's ability to amplify a signal.
- A Bipolar junction transistor is made of three layers of semiconductor material.
- A Bipolar transistor has an emitter electrode.

- The abbreviation "FET" stands for Field Effect Transistor.
- A Field effect transistor has a gate electrode.

T6C - Circuit diagrams / schematic symbols

- Schematic symbols are the name for standardized representations of components in an electrical wiring diagram.
- The symbols on an electrical circuit schematic diagram represent electrical components.
- The way components are interconnected is accurately represented in electrical circuit schematic diagrams.

In Figure T1:

- **Component 1 = Resistor**
- **Component 2 = Transistor**
- **Component 3 = Lamp**
- **Component 4 = Battery**

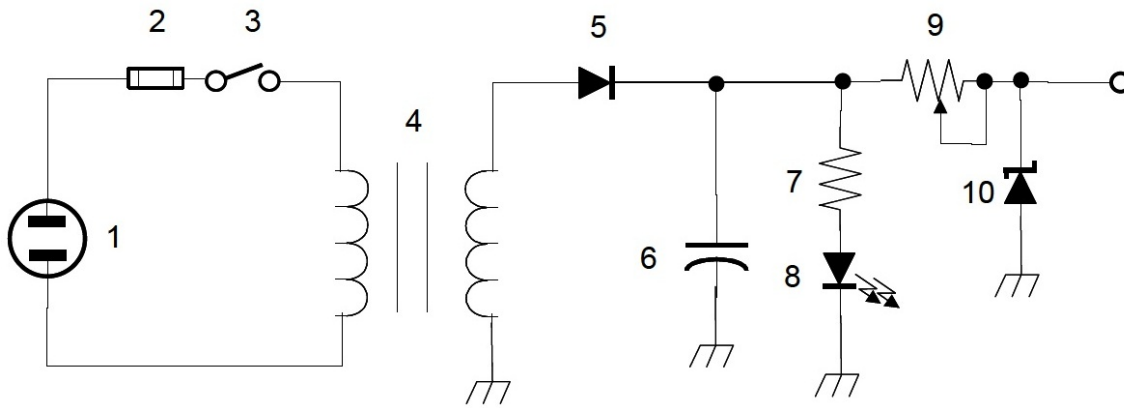
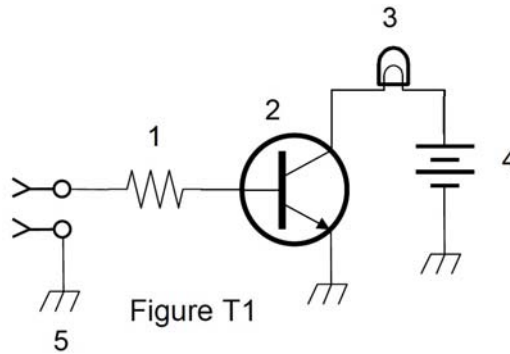

Figure T2

In Figure T2:

- **Component 3 = Single-pole single-throw Switch**
- **Component 4 = Transformer**
- **Component 6 = Capacitor**
- **Component 8 = Light emitting diode**
- **Component 9 = Variable resistor**

In Figure T3:

- **Component 3 = Variable inductor**
- **Component 4 = Antenna**

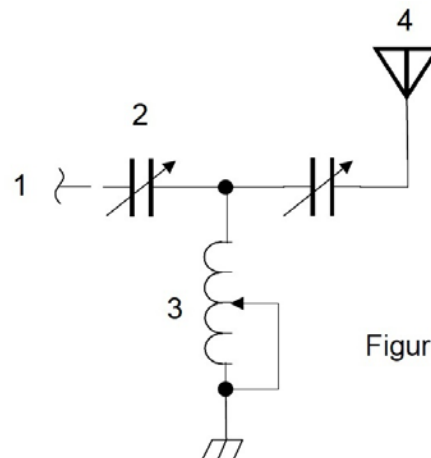

Figure T3

T6D - Component functions

- Rectifier devices or circuits change an alternating current into a varying direct current signal.
- A relay is a switch controlled by an electromagnet.
- A Meter can be used to display signal strength on a numeric scale.
- A Regulator circuit controls the amount of voltage from a power supply.
- A Transformer is commonly used to change 120V AC house current to a lower AC voltage for other uses.
- A LED is commonly used as a visual indicator.
- A Capacitor is used together with an inductor to make a tuned circuit.
- A Transistor (component 2 in Figure T1) controls the flow of current.
- An Integrated circuit is a device that combines several semiconductors and other components into one package.
- A common use of coaxial cable is to carry RF signals between a radio and antenna.

SUBELEMENT T7 - Station equipment; common transmitter and receiver problems, antenna measurements and troubleshooting, basic repair and testing - [4 Exam Questions - 4 Groups]

T7A - Station radios

Receivers

- The function of a product detector is to detect CW and SSB signals.
- Selectivity is the ability of a receiver to discriminate between multiple signals.
- An RF preamplifier installed between the antenna and receiver.

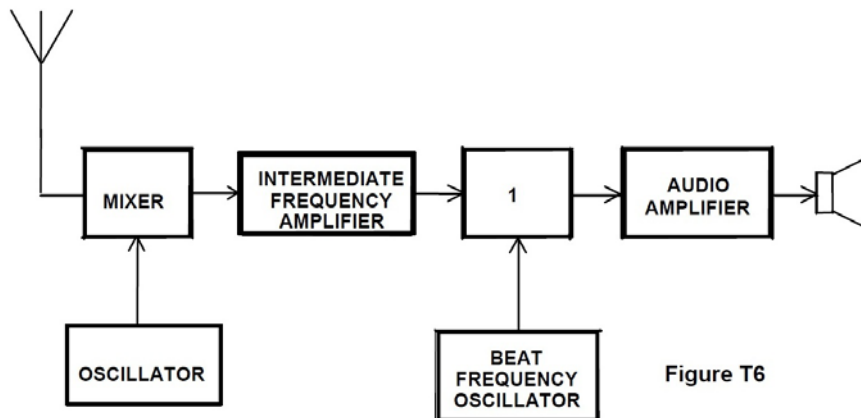

Figure T6

- A Single-conversion Superheterodyne receiver is shown in Figure T6.
- The function of a mixer in a superheterodyne receiver is to shift the incoming signal to an intermediate frequency.

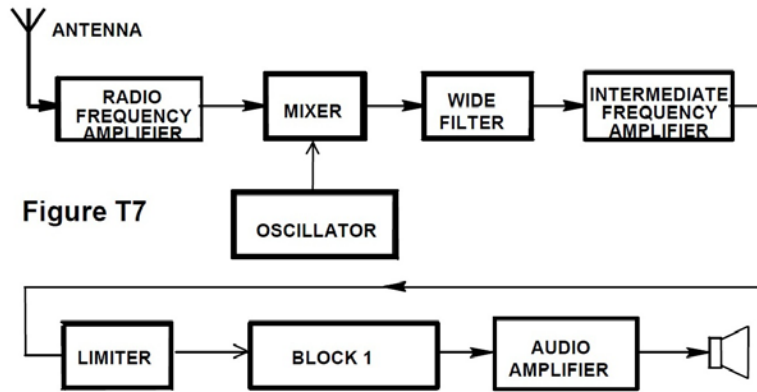

Figure T7

- If block 1 is a frequency discriminator, a superheterodyne receiver is pictured in Figure T7.
- A Discriminator demodulates FM signals.

Transmitters

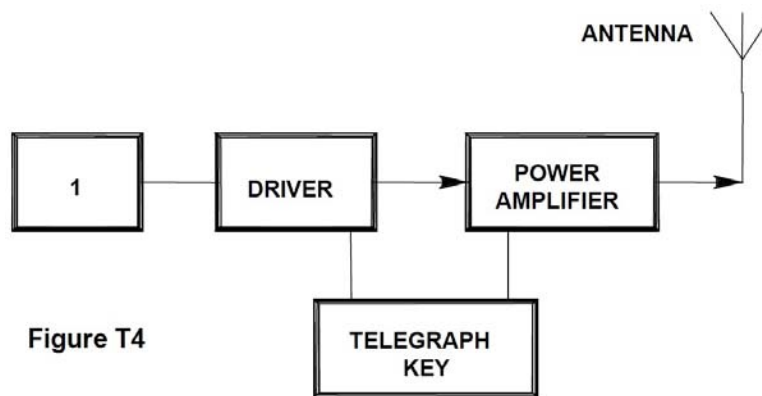

Figure T4

- If figure T4 is a simple CW transmitter, the function of block 1 is an Oscillator.

Transceivers

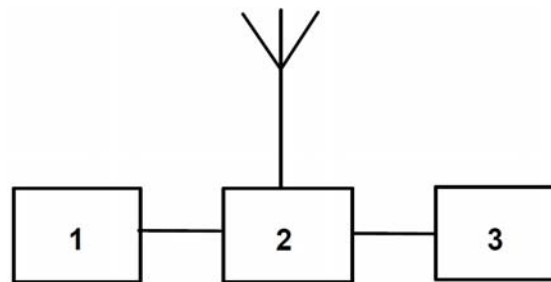

Figure T5

- Figure T5 represents a transceiver in which block 1 is the transmitter portion, block 2 is a transmit-receive switch, and block 3 is the receiver portion.
- A Modulator combines a speech signal and an RF carrier.
- A Transverter takes the output of a low-powered 28 MHz SSB exciter and produces a 222 MHz output signal.
- An RF power amplifier increases the low-power output from a handheld transceiver.
- A multi-mode VHF transceiver is most useful for VHF weak-signal communication.

T7B - Common transmitter and receiver problems, symptoms of overload and overdrive

Distortion

- ALL of these might be the problem if you receive a report that your audio signal through the repeater is distorted or unintelligible:
 - Your transmitter may be slightly off frequency
 - Your batteries may be running low
 - You could be in a bad location

Interference

- A fundamental overload in reference to a receiver is interference caused by very strong signals.
- ALL of the following may be a cause of radio frequency interference:
 - Fundamental overload
 - Harmonics
 - Spurious emissions
- The most likely cause of interference to a non-cordless telephone from a nearby transmitter is the telephone is inadvertently acting as a radio receiver.
- A logical first step when attempting to cure a radio frequency interference problem in a nearby telephone is to install an RF filter at the telephone.
- If someone tells you that your station's transmissions are interfering with their radio or TV reception, what you should do first is make sure that your station is functioning properly and that it does not cause interference to your own television.
- ALL of the following may be useful in correcting a radio frequency interference problem:
 - Snap-on ferrite chokes
 - Low-pass and high-pass filters
 - Band-reject and band-pass filters
- You should and could do all of the following if a "Part 15" device in your neighbor's home is causing harmful interference to your amateur station:
 - Work with your neighbor to identify the offending device
 - Politely inform your neighbor about the rules that require him to stop using the device if it causes interference
 - Check your station and make sure it meets the standards of good amateur practice

Over and under modulation

- If you are told your FM handheld or mobile transceiver is over deviating talk farther away from the microphone.

RF feedback

- A symptom of RF feedback in a transmitter or transceiver is reports of garbled, distorted, or unintelligible transmissions.

Off frequency signals, fading and noise

- If another operator reports a variable high-pitched whine on the audio from your mobile transmitter, what could be happening is noise on the vehicle's electrical system is being transmitted along with your speech audio.

Problems with digital communications interfaces

- The acronym "BER" means Bit Error Rate when applied to digital communications systems.

T7C - Antenna measurements and troubleshooting

Dummy loads

- The primary purpose of a dummy load is to prevent the radiation of signals when making tests.

Measuring SWR

- An antenna analyzer can be used to determine if an antenna is resonant at the desired operating frequency.
- In general terms, standing wave ratio (SWR) is a measure of how well a load is matched to a transmission line.
- A reading of 1 to 1 on an SWR meter indicates a perfect impedance match between the antenna and the feedline.
- The approximate SWR value above which the protection circuits in most solid-state transmitters begin to reduce transmitter power is 2 to 1.
- An SWR reading of 4:1 means there is an impedance mismatch.
- An instrument, other than an SWR meter, that you could use to determine if a feedline and antenna are properly matched is a directional wattmeter.

Feedline failure modes

- Power lost in a feedline is converted into heat.
- The most common cause for failure of coaxial cables is moisture contamination.
- The outer jacket of coaxial cable should be resistant to ultraviolet light because ultraviolet light can damage the jacket and allow water to enter the cable.
- A disadvantage of "air core" coaxial cable when compared to foam or solid dielectric types is that it requires special techniques to prevent water absorption.

T7D - Basic repair and testing

Soldering

- Rosin-core solder is best for radio and electronic use.
- A grainy or dull surface is the characteristic appearance of a "cold" solder joint.

Use of a voltmeter

- The instrument you would use to measure electric potential or electromotive force is a voltmeter.
- The correct way to connect a voltmeter to a circuit is in parallel with the circuit.

Use of an ammeter

- An ammeter is usually connected in series with the circuit.
- An ammeter is used to measure electric current.

Use of an ohmmeter

- An ohmmeter is used to measure resistance.
- When an ohmmeter, connected across a circuit, initially indicates a low resistance and then shows increasing resistance with time the circuit contains a large capacitor.
- A precaution that should be taken when measuring circuit resistance with an ohmmeter is to ensure that the circuit is not powered.

Multimeter

- Voltage and resistance measurements are commonly made using a multimeter. A multimeter is a multiple function meter which may include capability to measure voltage, current and resistance.
- Attempting to measure voltage when using the resistance setting might damage a multimeter.

SUBELEMENT T8 - Modulation modes; amateur satellite operation, operating activities, non-voice communications - [4 Exam Questions - 4 Groups]

T8A - Modulation modes, bandwidth of various signals

Modulation Modes

- FM is most commonly used for VHF and UHF voice repeaters.
- Frequency modulation (FM) is most commonly used for VHF packet radio transmissions.
- Single sideband (SSB) is a form of amplitude modulation (AM).
- SSB voice modulation is most often used for long-distance or weak signal contacts on the VHF and UHF bands.
- Upper sideband (USB) is normally used for 10 meter HF, VHF and UHF single-sideband communications.
- The primary advantage of single sideband over FM for voice transmissions is SSB signals have narrower bandwidth.
- In comparison to SSB and FM, CW emission has the narrowest bandwidth.

Bandwidth of various signals

- The typical bandwidth of analog fast-scan TV transmissions on the 70 cm band is about 6 MHz.
- The approximate bandwidth of a VHF repeater FM phone signal is between 5 and 15 kHz.
- The approximate bandwidth of a single sideband voice signal is 3 kHz.
- The approximate maximum bandwidth required to transmit a CW signal is 150 Hz.

T8B - Amateur satellite operation

Basic orbits

- The initials LEO tell you that an amateur satellite is in a Low Earth Orbit (LEO).

Doppler shift / Spin Fading

- With regard to satellite communications, Doppler shift is an observed change in signal frequency caused by relative motion between the satellite and the earth station.
- When referring to satellite signals, rotation of the satellite and its antennas causes "spin fading".

Operating protocols

- Any amateur whose license privileges allow them to transmit on the satellite uplink frequency may be the control operator of a station communicating through an amateur satellite or space station.
- The minimum amount of transmitter power needed to complete the contact should be used on the uplink frequency of an amateur satellite or space station. [97.313(a)]
- Using an amateur radio satellite you can talk to amateur radio operators in other countries.

- Any amateur holding a Technician or higher class license may make contact with an amateur station on the International Space Station using 2 meter and 70 cm band amateur radio frequencies.
- The statement that a satellite is operating in "mode U/V" means the satellite uplink is in the 70 cm band and the downlink is in the 2 meter band.
- A commonly used method of sending signals to and from a digital satellite is FM Packet.
- A satellite beacon is a transmission from a space station that contains information about a satellite.
- A satellite tracking program can be used to determine the time period during which an amateur satellite or space station can be accessed.

T8C - Operating activities

Contests

- Contesting is a popular operating activity involving contacting as many stations as possible during a specified period of time.
- A grid locator is a letter-number designator assigned to a geographic location.
- A good procedure when contacting another station in a radio contest is to send only the minimum information needed for proper identification and the contest exchange.

Special event stations

- A temporary "1 by 1" format (letter-number-letter) call sign can be assigned for operations in conjunction with an activity of special significance to the amateur community.

Radio direction finding

- Radio direction finding is a method used to locate sources of noise interference or jamming.
- A directional antenna would be useful for a hidden transmitter hunt.

Radio control

- The maximum power allowed when transmitting telecommand signals to radio controlled models is 1 watt. [97.215(c)]
- A label indicating the licensee's name, call sign and address must be affixed to the transmitter in place of on-air station identification when sending signals to a radio control model using amateur frequencies. [97.215(a)]

Basic linking over Internet

- You might obtain a list of active nodes that use VoIP from a repeater directory.
- You select a specific IRLP node when using a portable transceiver by using the keypad to transmit the IRLP node ID.
- A gateway is an amateur radio station that is used to connect other amateur stations to the Internet.

T8D - Non-voice communications

Data

- The emission mode, Data, may be used by a Technician Class operator between 219 and 220 MHz.

Image data

- The type of transmission indicated by the term NTSC is an analog fast scan color TV signal.

Digital modes

- ALL of the following are examples of digital communication methods:
 - Packet
 - PSK31
 - MFSK

CW

- International Morse code is used when sending CW in the amateur bands.
- ALL of the following can be used to transmit CW in the amateur bands:
 - Straight Key
 - Electronic Keyer
 - Computer Keyboard

PSK31

- The abbreviation PSK means Phase Shift Keying.
- PSK31 is a low-rate data transmission mode.

Packet

- ALL of the following may be included in packet transmissions:
 - A check sum which permits error detection
 - A header which contains the call sign of the station to which the information is being sent
 - Automatic repeat request in case of error
- A "parity" bit is an extra code element used to detect errors in received data.

APRS

- The term APRS means Automatic Position Reporting System.
- A Global Positioning System receiver is normally used when sending automatic location reports via amateur radio.

SUBELEMENT T9 - Antennas, feedlines - [2 Exam Questions – 2 Groups]

T9A – Antennas

Vertical and horizontal

- For vertical antennas, the electric field is perpendicular to the Earth.
- A simple dipole mounted so the conductor is parallel to the Earth's surface is a horizontally polarized antenna.

Concept of gain

- A beam antenna is an antenna that concentrates signals in one direction.
- The quad, Yagi, and dish are all types of directional antennas.
- The radiation is strongest from a half-wave dipole antenna, in free space, broadside to the antenna.
- The gain of an antenna is the increase in signal strength in a specified direction when compared to a reference antenna.

Common portable and mobile antennas

- A disadvantage of the "rubber duck" antenna supplied with most handheld radio transceivers is it does not transmit or receive as effectively as a full-sized antenna.

- A good reason NOT to use a "rubber duck" antenna inside your car is that signals can be significantly weaker than when it is outside of the vehicle.

Relationships between antenna length and frequency

- You would shorten a dipole antenna to make it resonant on a higher frequency.
- The approximate length of a quarter-wavelength vertical antenna for 146 MHz is 19 inches.
- The approximate length of a 6 meter 1/2-wavelength wire dipole antenna is 112 inches.

T9B – Feedlines

Types

- Coaxial cable is used more often than any other feedline for amateur radio antenna systems because it is easy to use and requires few special installation considerations.
- The impedance of the most commonly used coaxial cable in typical amateur radio installations is 50 ohms.
- Air-insulated hard line types of feedline have the lowest loss at VHF and UHF.

Losses vs. frequency

- Generally, the loss increases as the frequency of a signal passing through coaxial cable is increased.
- The primary electrical difference between the smaller RG-58 and larger RG-8 coaxial cables is that RG-8 cable has less loss at a given frequency.

SWR concepts

- It is important to have a low SWR in an antenna system that uses coaxial cable feedline to allow the efficient transfer of power and reduce losses.
- An antenna tuner matches the antenna system impedance to the transceiver's output impedance.
- A loose connection in an antenna or a feedline might cause erratic changes in SWR readings.

Connectors

- A Type N connector is most suitable for frequencies above 400 MHz.
- The PL-259 type coax connectors are commonly used at HF frequencies.

Matching weather protection

- Coax connectors exposed to the weather should be sealed against water intrusion to prevent an increase in feedline loss.

SUBELEMENT T0 - AC power circuits, antenna installation, RF hazards – [3 Exam Questions - 3 Groups]

T0A - AC power circuits / electrical code compliance

Hazardous voltages

- A commonly accepted value for the lowest voltage that can cause a dangerous electric shock 30 volts.

(Author's comment: Never bet your life on rules-of-thumb like this. Ultimately, there are many factors besides voltage level that can affect your safety.)

- Current flowing through the body can cause a health hazard all of the following:
 - By heating tissue
 - It disrupts the electrical functions of cells

- It causes involuntary muscle contractions
- A hazard that might exist in a power supply when it is turned off and disconnected is that you could still receive an electric shock from stored charge in large capacitors.

Fuses and circuit breakers

- The purpose of a fuse in an electrical circuit is to interrupt power in case of overload.
- It is unwise to install a 20-ampere fuse in the place of a 5-ampere fuse because excessive current could cause a fire.
- A fuse or circuit breaker in series with the AC "hot" conductor should always be included in home-built equipment that is powered from 120V AC power circuits.

Grounding

- Safety ground is connected to the green wire in a three-wire electrical AC plug.
- ALL of these are a good way to guard against electrical shock at your station:
 - Use three-wire cords and plugs for all AC powered equipment
 - Connect all AC powered station equipment to a common safety ground
 - Use a circuit protected by a ground-fault interrupter

Lightning protection

- Precautions that should be taken when installing devices for lightning protection in a coaxial cable feedline include grounding all of the protectors to a common plate which is in turn connected to an external ground.
- A good practice when installing ground wires on a tower for lightning protection is to ensure that connections are short and direct.

Battery safety

- If the commercial power is out, one way to recharge a 12-volt lead-acid station battery is by connecting the battery to a car's battery and running the engine
- If a conventional 12-volt storage battery is not properly vented, explosive gas can collect and present a hazard.
- If a lead-acid storage battery is charged or discharged too quickly, the battery could overheat and give off flammable gas or explode.

T0B - Antenna installation

Tower safety

- Members of a tower work team should wear a hard hat and safety glasses at all times when any work is being done on the tower.
- A good precaution to observe before climbing an antenna tower is put on a climbing harness and safety glasses.
- It is never safe to climb a tower without a helper or observer.
- An important safety precaution to observe when putting up an antenna tower is look for and stay clear of any overhead electrical wires.
- The purpose of a gin pole is to lift tower sections or antennas.
- An important safety rule to remember when using a crank-up tower is this type of tower must never be climbed unless it is in the fully retracted position.
- A separate eight-foot long ground rods for each tower leg, bonded to the tower and each other, is considered to be a proper grounding method for a tower.

Overhead power lines

- The minimum safe distance from a power line to allow when installing an antenna is so that if the antenna falls unexpectedly, no part of it can come closer than 10 feet to the power wires.

- You should avoid attaching an antenna to a utility pole because the antenna could contact high-voltage power wires.
- Sharp bends must be avoided concerning grounding conductors used for lightning protection.
- Local electrical codes establish grounding requirements for an amateur radio tower or antenna

T0C - RF hazards

Radiation exposure/Exposure to others/Recognized safe power levels

- VHF and UHF radio signals are non-ionizing radiation.
- The frequency, 50 MHz, has the lowest Maximum Permissible Exposure limit.
- The maximum power level that an amateur radio station may use at VHF frequencies before an RF exposure evaluation is required is 50 watts PEP at the antenna.
- Exposure limits vary with frequency because the human body absorbs more RF energy at some frequencies than at others.
- Duty cycle is one of the factors used to determine safe RF radiation exposure levels because it affects the average exposure of people to radiation.
- When referring to RF exposure, duty cycle is the ratio of on-air time to total operating time of a transmitted signal.
- ALL of these are acceptable methods to determine that your station complies with FCC RF exposure regulations:
 - By calculation based on FCC OET Bulletin 65
 - By calculation based on computer modeling
 - By measurement of field strength using calibrated equipment
- You can make sure your station stays in compliance with RF safety regulations by re-evaluating the station whenever an item of equipment is changed.

Proximity to antennas

- ALL of these factors affect the RF exposure of people near an amateur station antenna:
 - Frequency and power level of the RF field
 - Distance from the antenna to a person
 - Radiation pattern of the antenna
- If a person accidentally touched your antenna while you were transmitting they might receive a painful RF burn.
- An action amateur operators might take to prevent exposure to RF radiation in excess of FCC-supplied limits includes relocating the antenna.