

# HamElmer.com

This document displays the Technicians question pool in a Question and Answer format.

Only the question and correct answer is presented.

Valid from July 1, 2010 to June 30, 2014

Download other free study materials for U.S.A. Amateur Radio tests at <http://HamElmer.com>

Paul Guido, HamElmer.com Editor, N5IUT

Compact Version 2.1  
FIRST PRINTING – January 2010

This document is available for any non-profit and non-commercial use. Please email any corrections or omissions to [RadioTeacher@gmail.com](mailto:RadioTeacher@gmail.com)

The source data used to create this document is available to the public: Technicians Question Pool (Released January 4, 2010) for tests after July 1, 2010 until June 30, 2014. <http://www.ncvec.org/>

If you have any questions or comments please post a message at <http://groups.yahoo.com/group/HamElmer/>

[If you would like a 18 page version of this document with smaller fonts and graphics click here.](#)

The HamElmer logo: From the center out is the Summary of Ohm's Law, Angle in degrees and the sine of the angle, Resistor color codes, 24 hour clock face and a compass rose.

January 10, 2010

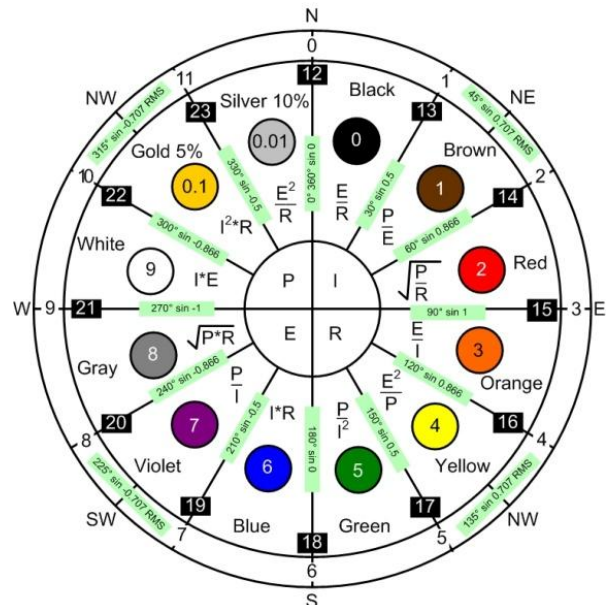

## **Table of Contents**

T1A - Amateur Radio services; purpose of the amateur service, amateur-satellite service, operator/primary station license grant, where FCC rules are codified, basis and purpose of FCC rules, meanings of basic terms used in FCC rules.....	4
T1B - Authorized frequencies; frequency allocations, ITU regions, emission type, restricted sub-bands, spectrum sharing, transmissions near band edges .....	5
T1C - Operator classes and station call signs; operator classes, sequential, special event, and vanity call sign systems, international communications, reciprocal operation, station license and licensee, places where the amateur service is regulated by the FCC, name and address on ULS, license term, renewal, grace period .....	6
T1D - Authorized and prohibited transmissions .....	7
T1E - Control operator and control types; control operator required, eligibility, designation of control operator, privileges and duties, control point, local, automatic and remote control, location of control operator.....	8
T1F - Station identification and operation standards; special operations for repeaters and auxiliary stations, third party communications, club stations, station security, FCC inspection.....	9
T2A - Station operation; choosing an operating frequency, calling another station, test transmissions, use of minimum power, frequency use, band plans.....	10
T2B – VHF/UHF operating practices; SSB phone, FM repeater, simplex, frequency offsets, splits and shifts, CTCSS, DTMF, tone squelch, carrier squelch, phonetics .....	11
T2C – Public service; emergency and non-emergency operations, message traffic handling .....	12
T3A - Radio wave characteristics; how a radio signal travels; distinctions of HF, VHF and UHF; fading, multipath; wavelength vs. penetration; antenna orientation .....	13
T3B - Radio and electromagnetic wave properties; the electromagnetic spectrum, wavelength vs. frequency, velocity of electromagnetic waves .....	14
T3C - Propagation modes; line of sight, sporadic E, meteor, aurora scatter, tropospheric ducting, F layer skip, radio horizon .....	15
T4A – Station setup; microphone, speaker, headphones, filters, power source, connecting a computer, RF grounding.....	16
T4B - Operating controls; tuning, use of filters, squelch, AGC, repeater offset, memory channels.....	17
T5A - Electrical principles; current and voltage, conductors and insulators, alternating and direct current .....	18
T5B - Math for electronics; decibels, electrical units and the metric system .....	19
T5C - Electronic principles; capacitance, inductance, current flow in circuits, alternating current, definition of RF, power calculations .....	20
T5D – Ohm’s Law.....	21

## HamElmer.com Technician Q&A Format

T6A - Electrical components; fixed and variable resistors, capacitors, and inductors; fuses, switches, batteries .....	22
T6B – Semiconductors; basic principles of diodes and transistors .....	23
T6C - Circuit diagrams; schematic symbols.....	24
T6D - Component functions.....	25
T7A - Station radios; receivers, transmitters, transceivers .....	26
T7B – Common transmitter and receiver problems; symptoms of overload and overdrive, distortion, interference, over and under modulation, RF feedback, off frequency signals; fading and noise; problems with digital communications interfaces .....	27
T7C – Antenna measurements and troubleshooting; measuring SWR, dummy loads, feedline failure modes .....	28
T7D – Basic repair and testing; soldering, use of a voltmeter, ammeter, and ohmmeter .....	29
T8A – Modulation modes; bandwidth of various signals .....	30
T8B - Amateur satellite operation; Doppler shift, basic orbits, operating protocols.....	31
T8C – Operating activities; radio direction finding, radio control, contests, special event stations, basic linking over Internet .....	32
T8D – Non-voice communications; image data, digital modes, CW, packet, PSK31 .....	33
T9A – Antennas; vertical and horizontal, concept of gain, common portable and mobile antennas, relationships between antenna length and frequency .....	34
T9B - Feedlines; types, losses vs. frequency, SWR concepts, matching weather protection, connectors .....	35
T0A – AC power circuits; hazardous voltages, fuses and circuit breakers, grounding, lightning protection, battery safety, electrical code compliance .....	36
T0B – Antenna installation; tower safety, overhead power lines .....	37
T0C - RF hazards; radiation exposure, proximity to antennas, recognized safe power levels, exposure to others .....	38
Graphics for 2010 Technician Question Pool – Exam Element 2 Effective July 1, 2010 .....	39
Index.....	42

## HamElmer.com Technician Q&A Format

### **T1A - Amateur Radio services; purpose of the amateur service, amateur-satellite service, operator/primary station license grant, where FCC rules are codified, basis and purpose of FCC rules, meanings of basic terms used in FCC rules**

For whom is the Amateur Radio Service intended?

Persons who are interested in radio technique solely with a personal aim and without pecuniary interest

What agency regulates and enforces the rules for the Amateur Radio Service in the United States?

The FCC

Which part of the FCC rules contains the rules and regulations governing the Amateur Radio Service?

Part 97

Which of the following meets the FCC definition of harmful interference?

That which seriously degrades, obstructs, or repeatedly interrupts a radio communication service operating in accordance with the Radio Regulations

What is the FCC part 97 definition of a space station?

An amateur station located more than 50 km above the Earth's surface

What is the FCC part 97 definition of telecommand?

A one-way transmission to initiate, modify or terminate functions of a device at a distance

What is the FCC part 97 definition of telemetry?

A one-way transmission of measurements at a distance from the measuring instrument

Which of the following entities recommends transmit/receive channels and other parameters for auxiliary and repeater stations?

Frequency Coordinator

Who selects a frequency coordinator?

Amateur operators in a local or regional area that are eligible to be auxiliary or repeater stations

What is the FCC part 97 definition of an amateur station?

A station in an Amateur Radio Service consisting of the apparatus necessary for carrying on radio communications

Which of the following stations transmits signals over the air from a remote receive site to a repeater for retransmission?

Auxiliary station

## HamElmer.com Technician Q&A Format

### **T1B - Authorized frequencies; frequency allocations, ITU regions, emission type, restricted sub-bands, spectrum sharing, transmissions near band edges**

What is the ITU?

[A United Nations agency for information and communication technology issues](#)

North American amateur stations are located in which ITU region?

[Region 2](#)

Which frequency is within the 6 meter band?

[52.525 MHz](#)

Which amateur band are you using when your station is transmitting on 146.52 MHz?

[2 meter band](#)

Which 70 cm frequency is authorized to a Technician Class license holder operating in ITU Region 2?

[443.350 MHz](#)

Which 23 cm frequency is authorized to a Technician Class operator license?

[1296 MHz](#)

What amateur band are you using if you are transmitting on 223.50 MHz?

[1.25 meter band](#)

What do the FCC rules mean when an amateur frequency band is said to be available on a secondary basis?

[Amateurs may not cause harmful interference to primary users](#)

Why should you not set your transmit frequency to be exactly at the edge of an amateur band or sub-band?

[To allow for calibration error in the transmitter frequency display](#)

[So that modulation sidebands do not extend beyond the band edge](#)

[To allow for transmitter frequency drift](#)

[“All of these choices are correct”](#)

Which of the bands available to Technician Class operators have mode-restricted sub-bands?

[The 6 meter, 2 meter, and 1.25 meter bands](#)

What emission modes are permitted in the mode-restricted sub-bands at 50.0 to 50.1 MHz and 144.0 to 144.1 MHz?

[CW only](#)

## HamElmer.com Technician Q&A Format

**T1C - Operator classes and station call signs; operator classes, sequential, special event, and vanity call sign systems, international communications, reciprocal operation, station license and licensee, places where the amateur service is regulated by the FCC, name and address on ULS, license term, renewal, grace period**

Which type of call sign has a single letter in both the prefix and suffix?

[Special event](#)

Which of the following is a valid US amateur radio station call sign?

[W3ABC](#)

What types of international communications are permitted by an FCC-licensed amateur station?

[Communications incidental to the purposes of the amateur service and to remarks of a personal character](#)

When are you allowed to operate your amateur station in a foreign country?

[When the foreign country authorizes it](#)

What must you do if you are operating on the 23 cm band and learn that you are interfering with a radiolocation station outside the United States?

[Stop operating or take steps to eliminate the harmful interference](#)

From which of the following may an FCC-licensed amateur station transmit, in addition to places where the FCC regulates communications?

[From any vessel or craft that is documented or registered in the United States](#)

What may result when correspondence from the FCC is returned as undeliverable because the grantee failed to provide the correct mailing address?

[Revocation of the station license or suspension of the operator license](#)

What is the normal term for an FCC-issued primary station/operator license grant?

[Ten years](#)

What is the grace period following the expiration of an amateur license within which the license may be renewed?

[Two years](#)

How soon may you transmit after you pass the examination elements required for your first amateur radio license?

[As soon as your name and call sign appear in the FCC's ULS database](#)

If your license has expired and is still within the allowable grace period, may you continue to transmit?

[No, transmitting is not allowed until the ULS database shows that the license has been renewed](#)

## HamElmer.com Technician Q&A Format

### **T1D - Authorized and prohibited transmissions**

With which countries are FCC-licensed amateur stations prohibited from exchanging communications?

Any country whose administration has notified the ITU that it objects to such communications

On which of the following occasions may an FCC-licensed amateur station exchange messages with a U.S. military station?

During an Armed Forces Day Communications Test

When is the transmission of codes or ciphers allowed to hide the meaning of a message transmitted by an amateur station?

Only when transmitting control commands to space stations or radio control craft

What is the only time an amateur station is authorized to transmit music?

When incidental to an authorized retransmission of manned spacecraft communications

When may amateur radio operators use their stations to notify other amateurs of the availability of equipment for sale or trade?

When the equipment is normally used in an amateur station and such activity is not conducted on a regular basis

Which of the following types of transmissions are prohibited?

Transmissions that contain obscene or indecent words or language

When is an amateur station authorized to automatically retransmit the radio signals of other amateur stations?

When the signals are from an auxiliary, repeater, or space station

When may the control operator of an amateur station accept compensation?

When the communication is incidental to classroom instruction at an educational institution

Under which of the following circumstances are amateur stations authorized to transmit signals related to broadcasting, program production, or news gathering, assuming no other means is available?

Only where such communications directly relate to the immediate safety of human life or protection of property

What is the meaning of the term broadcasting in the FCC rules for the amateur services?

Transmissions intended for reception by the general public

Which of the following types of communications are permitted in the Amateur Radio Service?

Brief transmissions to make station adjustments

## HamElmer.com Technician Q&A Format

### **T1E - Control operator and control types; control operator required, eligibility, designation of control operator, privileges and duties, control point, local, automatic and remote control, location of control operator**

When must an amateur station have a control operator?

[Only when station is transmitting](#)

Who is eligible to be the control operator of an amateur station?

[Only a person for whom an amateur operator/primary station license grant appears in the FCC database or who is authorized for alien reciprocal operation](#)

Who must designate the station control operator?

[The station licensee](#)

What determines the transmitting privileges of an amateur station?

[The class of operator license held by the control operator](#)

What is an amateur station control point?

[The location at which the control operator function is performed](#)

Under which of the following types of control is it permissible for the control operator to be at a location other than the control point?

[Automatic control](#)

When the control operator is not the station licensee, who is responsible for the proper operation of the station?

[The control operator and the station licensee are equally responsible](#)

What type of control is being used for a repeater when the control operator is not present at a control point?

[Automatic control](#)

What type of control is being used when transmitting using a handheld radio?

[Local control](#)

What type of control is used when the control operator is not at the station location but can indirectly manipulate the operating adjustments of a station?

[Remote](#)

Who does the FCC presume to be the control operator of an amateur station, unless documentation to the contrary is in the station records?

[The station licensee](#)



## HamElmer.com Technician Q&A Format

### **T1F - Station identification and operation standards; special operations for repeaters and auxiliary stations, third party communications, club stations, station security, FCC inspection**

What type of identification is being used when identifying a station on the air as “Race Headquarters”?

[Tactical call](#)

When using tactical identifiers, how often must your station transmit the station’s FCC-assigned call sign?

[Every ten minutes](#)

When is an amateur station required to transmit its assigned call sign?

[At least every 10 minutes during and at the end of a contact](#)

Which of the following is an acceptable method of station identification when operating in the phone sub-band?

[By a phone emission in the English language](#)

What method of call sign identification is required for a station transmitting phone signals?

[Send the call sign using CW or phone emission](#)

Which of the following uses of a self-assigned indicator is acceptable when identifying using a phone transmission?

[KL7CC stroke W3, KL7CC slant W3 and KL7CC slash W3 “All of these choices are correct”](#)

Which of the following restrictions apply when appending a self-assigned call sign indicator?

[It must not conflict with any other indicator specified by the FCC rules or with any call sign prefix assigned to another country](#)

When may a Technician Class licensee be the control operator of a station operating in an exclusive Extra Class operator segment of the amateur bands?

[Never](#)

What type of amateur station simultaneously retransmits the signal of another amateur station on a different channel or channels?

[Repeater station](#)

Who is accountable should a repeater inadvertently retransmit communications that violate the FCC rules?

[The control operator of the originating station](#)

To which foreign stations do the FCC rules authorize the transmission of non-emergency third party communications?

[Any station whose government permits such communications](#)

How many persons are required to be members of a club for a club station license to be issued by the FCC?

[At least 4](#)

When must the station licensee make the station and its records available for FCC inspection?

[Any time upon request by an FCC representative](#)

## HamElmer.com Technician Q&A Format

### **T2A - Station operation; choosing an operating frequency, calling another station, test transmissions, use of minimum power, frequency use, band plans**

What is the most common repeater frequency offset in the 2 meter band?

Plus or minus 600 kHz

What is the national calling frequency for FM simplex operations in the 70 cm band?

446.000 MHz

What is a common repeater frequency offset in the 70 cm band?

Plus or minus 5 MHz

What is an appropriate way to call another station on a repeater if you know the other station's call sign?

Say the station's call sign then identify with your call sign

What should you transmit when responding to a call of CQ?

The other station's call sign followed by your call sign

What must an amateur operator do when making on-air transmissions to test equipment or antennas?

Properly identify the transmitting station

Which of the following is true when making a test transmission?

Station identification is required at least every ten minutes during the test and at the end

What is the meaning of the procedural signal "CQ"?

Calling any station

What brief statement is often used in place of "CQ" to indicate that you are listening on a repeater?

Say your call sign

What is a band plan, beyond the privileges established by the FCC?

A voluntary guideline for using different modes or activities within an amateur band

What are the FCC rules regarding power levels used in the amateur bands?

An amateur must use the minimum transmitter power necessary to carry out the desired communication

## HamElmer.com Technician Q&A Format

### **T2B – VHF/UHF operating practices; SSB phone, FM repeater, simplex, frequency offsets, splits and shifts, CTCSS, DTMF, tone squelch, carrier squelch, phonetics**

What is the term used to describe an amateur station that is transmitting and receiving on the same frequency?

[Simplex communication](#)

What is the term used to describe the use of a sub-audible tone transmitted with normal voice audio to open the squelch of a receiver?

[CTCSS](#)

Which of the following describes the muting of receiver audio controlled solely by the presence or absence of an RF signal?

[Carrier squelch](#)

What common problem causes you to be able to hear but not access a repeater even when transmitting with the proper offset?

[The repeater receiver requires audio tone burst for access](#)

[The repeater receiver requires a CTCSS tone for access](#)

[The repeater receiver may require a DCS tone sequence for access](#)

[“All of these choices are correct”](#)

What determines the amount of deviation of an FM signal?

[The amplitude of the modulating signal](#)

What happens when the deviation of an FM transmitter is increased?

[Its signal occupies more bandwidth](#)

What should you do if you receive a report that your station's transmissions are causing splatter or interference on nearby frequencies?

[Check your transmitter for off-frequency operation or spurious emissions](#)

What is the proper course of action if your station's transmission unintentionally interferes with another station?

[Properly identify your transmission and move to a different frequency](#)

Which of the following methods is encouraged by the FCC when identifying your station when using phone?

[Use of a phonetic alphabet](#)

What is the "Q" signal used to indicate that you are receiving interference from other stations?

[QRM](#)

What is the "Q" signal used to indicate that you are changing frequency?

[QSY](#)

**T2C – Public service; emergency and non-emergency operations, message traffic handling**

What set of rules applies to proper operation of your station when using amateur radio at the request of public service officials?

[FCC Rules](#)

Who must submit the request for a temporary waiver of Part 97.113 to allow amateur radio operators to provide communications on behalf of their employers during a government sponsored disaster drill?

[The government agency sponsoring the event](#)

When is it legal for an amateur licensee to provide communications on behalf of their employer during a government sponsored disaster drill or exercise?

[Only when the FCC has granted a government-requested waiver](#)

What do RACES and ARES have in common?

[Both organizations may provide communications during emergencies](#)

What is the Radio Amateur Civil Emergency Service?

[A radio service using amateur stations for emergency management or civil defense communications](#)

Which of the following is common practice during net operations to get the immediate attention of the net control station when reporting an emergency?

[Begin your transmission with "Priority" or "Emergency" followed by your call sign](#)

What should you do to minimize disruptions to an emergency traffic net once you have checked in?

[Do not transmit on the net frequency until asked to do so by the net control station](#)

What is usually considered to be the most important job of an amateur operator when handling emergency traffic messages?

[Passing messages exactly as written, spoken or as received](#)

When may an amateur station use any means of radio communications at its disposal for essential communications in connection with immediate safety of human life and protection of property?

[When normal communications systems are not available](#)

What is the preamble in a formal traffic message?

[The information needed to track the message as it passes through the amateur radio traffic handling system](#)

What is meant by the term "check" in reference to a formal traffic message?

[The check is a count of the number of words in the message](#)

**T3A - Radio wave characteristics; how a radio signal travels; distinctions of HF, VHF and UHF; fading, multipath; wavelength vs. penetration; antenna orientation**

What should you do if another operator reports that your stations' 2 meter signals were strong just a moment ago, but now they are weak or distorted?

Try moving a few feet, as random reflections may be causing multi-path distortion

Why are UHF signals often more effective from inside buildings than VHF signals?

The shorter wavelength allows them to more easily penetrate the structure of buildings

What antenna polarization is normally used for long-distance weak-signal CW and SSB contacts using the VHF and UHF bands?

Horizontal

What can happen if the antennas at opposite ends of a VHF or UHF line of sight radio link are not using the same polarization?

Signals could be significantly weaker

When using a directional antenna, how might your station be able to access a distant repeater if buildings or obstructions are blocking the direct line of sight path?

Try to find a path that reflects signals to the repeater

What term is commonly used to describe the rapid fluttering sound sometimes heard from mobile stations that are moving while transmitting?

Picket fencing

What type of wave carries radio signals between transmitting and receiving stations?

Electromagnetic

What is the cause of irregular fading of signals from distant stations during times of generally good reception?

Random combining of signals arriving via different path lengths

Which is the common effect of "skip" reflections between the Earth and the ionosphere?

The polarization of the original signal is randomized

What may occur if VHF or UHF data signals propagate over multiple paths?

Error rates are likely to increase

Which part of the atmosphere enables the propagation of radio signals around the world?

The ionosphere

**T3B - Radio and electromagnetic wave properties; the electromagnetic spectrum, wavelength vs. frequency, velocity of electromagnetic waves**

What is the name for the distance a radio wave travels during one complete cycle?

Wavelength

What term describes the number of times per second that an alternating current reverses direction?

Frequency

What are the two components of a radio wave?

Electric and magnetic fields

How fast does a radio wave travel through free space?

At the speed of light

How does the wavelength of a radio wave relate to its frequency?

The wavelength gets shorter as the frequency increases

What is the formula for converting frequency to wavelength in meters?

Wavelength in meters equals 300 divided by frequency in megahertz

What property of radio waves is often used to identify the different frequency bands?

The approximate wavelength

What are the frequency limits of the VHF spectrum?

30 to 300 MHz

What are the frequency limits of the UHF spectrum?

300 to 3000 MHz

What frequency range is referred to as HF?

3 to 30 MHz

What is the approximate velocity of a radio wave as it travels through free space?

300,000,000 meters per second

**T3C - Propagation modes; line of sight, sporadic E, meteor, aurora scatter, tropospheric ducting, F layer skip, radio horizon**

Why are "direct" (not via a repeater) UHF signals rarely heard from stations outside your local coverage area?

UHF signals are usually not reflected by the ionosphere

Which of the following might be happening when VHF signals are being received from long distances?

Signals are being refracted from a sporadic E layer

What is a characteristic of VHF signals received via auroral reflection?

The signals exhibit rapid fluctuations of strength and often sound distorted

Which of the following propagation types is most commonly associated with occasional strong over-the-horizon signals on the 10, 6, and 2 meter bands?

Sporadic E

What is meant by the term "knife-edge" propagation?

Signals are partially refracted around solid objects exhibiting sharp edges

What mode is responsible for allowing over-the-horizon VHF and UHF communications to ranges of approximately 300 miles on a regular basis?

Tropospheric scatter

What band is best suited to communicating via meteor scatter?

6 meters

What causes "tropospheric ducting"?

Temperature inversions in the atmosphere

What is generally the best time for long-distance 10 meter band propagation?

During daylight hours

What is the radio horizon?

The distance at which radio signals between two points are effectively blocked by the curvature of the Earth

Why do VHF and UHF radio signals usually travel somewhat farther than the visual line of sight distance between two stations?

The Earth seems less curved to radio waves than to light

## HamElmer.com Technician Q&A Format

### **T4A – Station setup; microphone, speaker, headphones, filters, power source, connecting a computer, RF grounding**

Which of the following is true concerning the microphone connectors on amateur transceivers?  
[Some connectors include push-to-talk and voltages for powering the microphone](#)

What could be used in place of a regular speaker to help you copy signals in a noisy area?  
[A set of headphones](#)

Which is a good reason to use a regulated power supply for communications equipment?  
[It prevents voltage fluctuations from reaching sensitive circuits](#)

Where must a filter be installed to reduce harmonic emissions?  
[Between the transmitter and the antenna](#)

What type of filter should be connected to a TV receiver as the first step in trying to prevent RF overload from a nearby 2 meter transmitter?  
[Band-reject filter](#)

Which of the following would be connected between a transceiver and computer in a packet radio station?  
[Terminal node controller](#)

How is the computer's sound card used when conducting digital communications using a computer?  
[The sound card provides audio to the microphone input and converts received audio to digital form](#)

Which type of conductor is best to use for RF grounding?  
[Flat strap](#)

Which would you use to reduce RF current flowing on the shield of an audio cable?  
[Ferrite choke](#)

What is the source of a high-pitched whine that varies with engine speed in a mobile transceiver's receive audio?  
[The alternator](#)

Where should a mobile transceiver's power negative connection be made?  
[At the battery or engine block ground strap](#)



## HamElmer.com Technician Q&A Format

### **T4B - Operating controls; tuning, use of filters, squelch, AGC, repeater offset, memory channels**

What may happen if a transmitter is operated with the microphone gain set too high?

The output signal might become distorted

Which of the following can be used to enter the operating frequency on a modern transceiver?

The keypad or VFO knob

What is the purpose of the squelch control on a transceiver?

To mute receiver output noise when no signal is being received

What is a way to enable quick access to a favorite frequency on your transceiver?

Store the frequency in a memory channel

Which of the following would reduce ignition interference to a receiver?

Turn on the noise blanker

Which of the following controls could be used if the voice pitch of a single-sideband signal seems too high or low?

The receiver RIT or clarifier

What does the term "RIT" mean?

Receiver Incremental Tuning

What is the advantage of having multiple receive bandwidth choices on a multimode transceiver?

Permits noise or interference reduction by selecting a bandwidth matching the mode

Which of the following is an appropriate receive filter to select in order to minimize noise and interference for SSB reception?

2400 Hz

Which of the following is an appropriate receive filter to select in order to minimize noise and interference for CW reception?

500 Hz

Which of the following describes the common meaning of the term "repeater offset"?

The difference between the repeater's transmit and receive frequencies

**T5A - Electrical principles; current and voltage, conductors and insulators, alternating and direct current**

Electrical current is measured in which of the following units?

[Amperes](#)

Electrical power is measured in which of the following units?

[Watts](#)

What is the name for the flow of electrons in an electric circuit?

[Current](#)

What is the name for a current that flows only in one direction?

[Direct current](#)

What is the electrical term for the electromotive force (EMF) that causes electron flow?

[Voltage](#)

How much voltage does a mobile transceiver usually require?

[About 12 volts](#)

Which of the following is a good electrical conductor?

[Copper](#)

Which of the following is a good electrical insulator?

[Glass](#)

What is the name for a current that reverses direction on a regular basis?

[Alternating current](#)

Which term describes the rate at which electrical energy is used?

[Power](#)

What is the basic unit of electromotive force?

[The volt](#)

**T5B - Math for electronics; decibels, electrical units and the metric system**

How many milliamperes is 1.5 amperes?

1,500 milliamperes

What is another way to specify a radio signal frequency of 1,500,000 hertz?

1500 kHz

How many volts are equal to one kilovolt?

One thousand volts

How many volts are equal to one microvolt?

One one-millionth of a volt

Which of the following is equivalent to 500 milliwatts?

0.5 watts

If an ammeter calibrated in amperes is used to measure a 3000-milliampere current, what reading would it show?

3 amperes

If a frequency readout calibrated in megahertz shows a reading of 3.525 MHz, what would it show if it were calibrated in kilohertz?

3525 kHz

How many microfarads are 1,000,000 picofarads?

1 microfarad

What is the approximate amount of change, measured in decibels (dB), of a power increase from 5 watts to 10 watts?

3 dB

What is the approximate amount of change, measured in decibels (dB), of a power decrease from 12 watts to 3 watts?

6 dB

What is the approximate amount of change, measured in decibels (dB), of a power increase from 20 watts to 200 watts?

10 dB

**T5C - Electronic principles; capacitance, inductance, current flow in circuits, alternating current, definition of RF, power calculations**

What is the ability to store energy in an electric field called?

Capacitance

What is the basic unit of capacitance?

The farad

What is the ability to store energy in a magnetic field called?

Inductance

What is the basic unit of inductance?

The henry

What is the unit of frequency?

Hertz

What is the abbreviation that refers to radio frequency signals of all types?

RF

What is the usual name for electromagnetic waves that travel through space?

Radio waves

What is the formula used to calculate electrical power in a DC circuit?

Power (P) equals voltage (E) multiplied by current (I)

How much power is being used in a circuit when the applied voltage is 13.8 volts DC and the current is 10 amperes?

138 watts

How much power is being used in a circuit when the applied voltage is 12 volts DC and the current is 2.5 amperes?

30 watts

How many amperes are flowing in a circuit when the applied voltage is 12 volts DC and the load is 120 watts?

10 amperes

## T5D – Ohm's Law

What formula is used to calculate current in a circuit?

Current (I) equals voltage (E) divided by resistance (R)

What formula is used to calculate voltage in a circuit?

Voltage (E) equals current (I) multiplied by resistance (R)

What formula is used to calculate resistance in a circuit?

Resistance (R) equals voltage (E) divided by current (I)

What is the resistance of a circuit in which a current of 3 amperes flows through a resistor connected to 90 volts?

30 ohms

What is the resistance in a circuit for which the applied voltage is 12 volts and the current flow is 1.5 amperes?

8 ohms

What is the resistance of a circuit that draws 4 amperes from a 12-volt source?

3 ohms

What is the current flow in a circuit with an applied voltage of 120 volts and a resistance of 80 ohms?

1.5 amperes

What is the current flowing through a 100-ohm resistor connected across 200 volts?

2 amperes

What is the current flowing through a 24-ohm resistor connected across 240 volts?

10 amperes

What is the voltage across a 2-ohm resistor if a current of 0.5 amperes flows through it?

1 volt

What is the voltage across a 10-ohm resistor if a current of 1 ampere flows through it?

10 volts

What is the voltage across a 10-ohm resistor if a current of 2 amperes flows through it?

20 volts

## HamElmer.com Technician Q&A Format

### **T6A - Electrical components; fixed and variable resistors, capacitors, and inductors; fuses, switches, batteries**

What electrical component is used to oppose the flow of current in a DC circuit?

Resistor

What type of component is often used as an adjustable volume control?

Potentiometer

What electrical parameter is controlled by a potentiometer?

Resistance

What electrical component stores energy in an electric field?

Capacitor

What type of electrical component consists of two or more conductive surfaces separated by an insulator?

Capacitor

What type of electrical component stores energy in a magnetic field?

Inductor

What electrical component is usually composed of a coil of wire?

Inductor

What electrical component is used to connect or disconnect electrical circuits?

Switch

What electrical component is used to protect other circuit components from current overloads?

Fuse

What is the nominal voltage of a fully charged nickel-cadmium cell?

1.2 volts

Which battery type is not rechargeable?

Carbon-zinc

**T6B – Semiconductors; basic principles of diodes and transistors**

What class of electronic components is capable of using a voltage or current signal to control current flow?

Transistors

What electronic component allows current to flow in only one direction?

Diode

Which of these components can be used as an electronic switch or amplifier?

Transistor

Which of these components is made of three layers of semiconductor material?

Bipolar junction transistor

Which of the following electronic components can amplify signals?

Transistor

How is a semiconductor diode's cathode lead usually identified?

With a stripe

What does the abbreviation "LED" stand for?

Light Emitting Diode

What does the abbreviation "FET" stand for?

Field Effect Transistor

What are the names of the two electrodes of a diode?

Anode and cathode

Which semiconductor component has an emitter electrode?

Bipolar transistor

Which semiconductor component has a gate electrode?

Field effect transistor

What is the term that describes a transistor's ability to amplify a signal?

Gain

## T6C - Circuit diagrams; schematic symbols

What is the name for standardized representations of components in an electrical wiring diagram?

Schematic symbols

What is component 1 in figure T1?

Resistor

What is component 2 in figure T1?

Transistor

What is component 3 in figure T1?

Lamp

What is component 4 in figure T1?

Battery

What is component 6 in figure T2?

Capacitor

What is component 8 in figure T2?

Light emitting diode

What is component 9 in figure T2?

Variable resistor

What is component 4 in figure T2?

Transformer

What is component 3 in figure T3?

Variable inductor

What is component 4 in figure T3?

Antenna

What do the symbols on an electrical circuit schematic diagram represent?

Electrical components

Which of the following is accurately represented in electrical circuit schematic diagrams?

The way components are interconnected



## T6D - Component functions

Which of the following devices or circuits changes an alternating current into a varying direct current signal?

Rectifier

What best describes a relay?

A switch controlled by an electromagnet

What type of switch is represented by item 3 in figure T2?

Single-pole single-throw

Which of the following can be used to display signal strength on a numeric scale?

Meter

What type of circuit controls the amount of voltage from a power supply?

Regulator

What component is commonly used to change 120V AC house current to a lower AC voltage for other uses?

Transformer

Which of the following is commonly used as a visual indicator?

LED

What of the following is used together with an inductor to make a tuned circuit?

Capacitor

What is the name of a device that combines several semiconductors and other components into one package?

Integrated circuit

What is the function of component 2 in Figure T1?

Control the flow of current

What of the following is a common use of coaxial cable?

Carry RF signals between a radio and antenna

## HamElmer.com Technician Q&A Format

### **T7A - Station radios; receivers, transmitters, transceivers**

What is the function of a product detector?

Detect CW and SSB signals

What type of receiver is shown in Figure T6?

Single-conversion superheterodyne

What is the function of a mixer in a superheterodyne receiver?

To shift the incoming signal to an intermediate frequency

What circuit is pictured in Figure T7, if block 1 is a frequency discriminator?

An FM receiver

What is the function of block 1 if figure T4 is a simple CW transmitter?

Oscillator

What device takes the output of a low-powered 28 MHz SSB exciter and produces a 222 MHz output signal?

Transverter

If figure T5 represents a transceiver in which block 1 is the transmitter portion and block 3 is the receiver portion, what is the function of block 2?

A transmit-receive switch

Which of the following circuits combines a speech signal and an RF carrier?

Modulator

Which of the following devices is most useful for VHF weak-signal communication?

A multi-mode VHF transceiver

What device increases the low-power output from a handheld transceiver?

An RF power amplifier

Which of the following circuits demodulates FM signals?

Discriminator

Which term describes the ability of a receiver to discriminate between multiple signals?

Selectivity

Where is an RF preamplifier installed?

Between the antenna and receiver

**T7B – Common transmitter and receiver problems; symptoms of overload and overdrive, distortion, interference, over and under modulation, RF feedback, off frequency signals; fading and noise; problems with digital communications interfaces**

What can you do if you are told your FM handheld or mobile transceiver is over deviating?

Talk farther away from the microphone

What is meant by fundamental overload in reference to a receiver?

Interference caused by very strong signals

Which of the following may be a cause of radio frequency interference?

Fundamental overload, Harmonics, Spurious emissions."All of these choices are correct"

What is the most likely cause of interference to a telephone from a nearby transmitter?

The telephone is inadvertently acting as a radio receiver

What is a logical first step when attempting to cure a radio frequency interference problem in a nearby telephone?

Install an RF filter at the telephone

What should you do first if someone tells you that your transmissions are interfering with their radio or TV reception?

Make sure that your station is operating properly and that it does not cause interference to your own television

Which of the following may be useful in correcting a radio frequency interference problem?

Snap-on ferrite chokes, Low-pass and high-pass filters, Band-reject and band-pass filters "All of these choices are correct"

What should you do if a "Part 15" device in your neighbor's home is causing harmful interference to your amateur station?

Work with your neighbor to identify the offending device, Politely inform your neighbor about the rules that require him to stop using the device if it causes interference, Check your station and make sure it meets the standards of good amateur practice "All of these choices are correct"

What could be happening if another operator reports a variable high-pitched whine on the audio from your mobile transmitter?

Noise on the vehicle's electrical system is being transmitted along with your speech audio

What might be the problem if you receive a report that your signal through the repeater is distorted or unintelligible?

Your transmitter may be slightly off frequency, Your batteries may be running low, You could be in a bad location, "All of these choices are correct"

What is a symptom of RF feedback in a transmitter or transceiver?

Reports of garbled, distorted, or unintelligible transmissions

What does the acronym "BER" mean when applied to digital communications systems?

Bit Error Rate

**T7C – Antenna measurements and troubleshooting; measuring SWR, dummy loads, feedline failure modes**

What is the primary purpose of a dummy load?

To prevent the radiation of signals when making tests

Which of the following instruments can be used to determine if an antenna is resonant at the desired operating frequency?

An antenna analyzer

What, in general terms, is standing wave ratio (SWR)?

A measure of how well a load is matched to a transmission line

What reading on an SWR meter indicates a perfect impedance match between the antenna and the feedline?

1 to 1

What is the approximate SWR value above which the protection circuits in most solid-state transmitters begin to reduce transmitter power?

2 to 1

What does an SWR reading of 4:1 mean?

An impedance mismatch

What happens to power lost in a feedline?

It is converted into heat

What instrument other than an SWR meter could you use to determine if a feedline and antenna are properly matched?

Directional wattmeter

Which of the following is the most common cause for failure of coaxial cables?

Moisture contamination

Why should the outer jacket of coaxial cable be resistant to ultraviolet light?

Ultraviolet light can damage the jacket and allow water to enter the cable

What is a disadvantage of "air core" coaxial cable when compared to foam or solid dielectric types?

It requires special techniques to prevent water absorption

**T7D – Basic repair and testing; soldering, use of a voltmeter, ammeter, and ohmmeter**

Which instrument would you use to measure electric potential or electromotive force?

[A voltmeter](#)

What is the correct way to connect a voltmeter to a circuit?

[In parallel with the circuit](#)

How is an ammeter usually connected to a circuit?

[In series with the circuit](#)

Which instrument is used to measure electric current?

[An ammeter](#)

What instrument is used to measure resistance?

[An ohmmeter](#)

Which of the following might damage a multimeter?

[Attempting to measure voltage when using the resistance setting](#)

Which of the following measurements are commonly made using a multimeter?

[Voltage and resistance](#)

Which of the following types of solder is best for radio and electronic use?

[Rosin-core solder](#)

What is the characteristic appearance of a "cold" solder joint?

[A grainy or dull surface](#)

What is probably happening when an ohmmeter, connected across a circuit, initially indicates a low resistance and then shows increasing resistance with time?

[The circuit contains a large capacitor](#)

Which of the following precautions should be taken when measuring circuit resistance with an ohmmeter?

[Ensure that the circuit is not powered](#)

**T8A – Modulation modes; bandwidth of various signals**

Which of the following is a form of amplitude modulation?

Single sideband

What type of modulation is most commonly used for VHF packet radio transmissions?

FM

Which type of voice modulation is most often used for long-distance or weak signal contacts on the VHF and UHF bands?

SSB

Which type of modulation is most commonly used for VHF and UHF voice repeaters?

FM

Which of the following types of emission has the narrowest bandwidth?

CW

Which sideband is normally used for 10 meter HF, VHF and UHF single-sideband communications?

Upper sideband

What is the primary advantage of single sideband over FM for voice transmissions?

SSB signals have narrower bandwidth

What is the approximate bandwidth of a single sideband voice signal?

3 kHz

What is the approximate bandwidth of a VHF repeater FM phone signal?

Between 5 and 15 kHz

What is the typical bandwidth of analog fast-scan TV transmissions on the 70 cm band?

About 6 MHz

What is the approximate maximum bandwidth required to transmit a CW signal?

150 Hz

## HamElmer.com Technician Q&A Format

### **T8B - Amateur satellite operation; Doppler shift, basic orbits, operating protocols**

Who may be the control operator of a station communicating through an amateur satellite or space station?

[Any amateur whose license privileges allow them to transmit on the satellite uplink frequency](#)

How much transmitter power should be used on the uplink frequency of an amateur satellite or space station?

[The minimum amount of power needed to complete the contact](#)

Which of the following can be done using an amateur radio satellite?

[Talk to amateur radio operators in other countries](#)

Which amateur stations may make contact with an amateur station on the International Space Station using amateur radio frequencies?

[Any amateur holding a Technician or higher class license](#)

What is a satellite beacon?

[A transmission from a space station that contains information about a satellite](#)

What can be used to determine the time period during which an amateur satellite or space station can be accessed?

[A satellite tracking program](#)

What is Doppler shift?

[A change in signal frequency caused by motion of the transmitting station](#)

What is meant by the statement that a satellite is operating in "mode U/V"?

[The satellite uplink is in the 70 cm band and the downlink is in the 2 meter band](#)

What causes "spin fading" when referring to satellite signals?

[Rotation of the satellite and its antennas](#)

What do the initials LEO tell you about an amateur satellite?

[The satellite is in a Low Earth Orbit](#)

What is a commonly used method of sending signals to and from a digital satellite?

[FM Packet](#)

## HamElmer.com Technician Q&A Format

### **T8C – Operating activities; radio direction finding, radio control, contests, special event stations, basic linking over Internet**

Which of the following methods is used to locate sources of noise interference or jamming?

[Radio direction finding](#)

Which of these items would be useful for a hidden transmitter hunt?

[A directional antenna](#)

What popular operating activity involves contacting as many stations as possible during a specified period of time?

[Contesting](#)

Which of the following is good procedure when contacting another station in a radio contest?

[Send only the minimum information needed for proper identification and the contest exchange](#)

What is a grid locator?

[A letter-number designator assigned to a geographic location](#)

For what purpose is a temporary "1 by 1" format (letter-number-letter) call sign assigned?

[For operations in conjunction with an activity of special significance to the amateur community](#)

What is the maximum power allowed when transmitting telecommand signals to radio controlled models?

[1 watt](#)

What is required in place of on-air station identification when sending signals to a radio control model using amateur frequencies?

[A label indicating the licensee's call sign and address must be affixed to the transmitter](#)

How might you obtain a list of active nodes that use VoIP?

[From a repeater directory](#)

How do you select a specific IRLP node when using a portable transceiver?

[Use the keypad to transmit the IRLP node ID](#)

What name is given to an amateur radio station that is used to connect other amateur stations to the Internet?

[A gateway](#)



**T8D – Non-voice communications; image data, digital modes, CW, packet, PSK31**

Which of the following is an example of a digital communications method?

Packet

PSK31

MFSK

“All of these choices are correct”

What does the term APRS mean?

Automatic Position Reporting System

Which of the following is normally used when sending automatic location reports via amateur radio?

A Global Positioning System receiver

What type of transmission is indicated by the term NTSC?

An analog fast scan color TV signal

Which of the following emission modes may be used by a Technician Class operator between 219 and 220 MHz?

Data

What does the abbreviation PSK mean?

Phase Shift Keying

What is PSK31?

A low-rate data transmission mode

What is included in packet transmissions?

A check sum which permits error detection

A header which contains the call sign of the station to which the information is being sent

Automatic repeat request in case of error

“All of these choices are correct”

What digital code is used when sending CW in the amateur bands?

Morse

Which of the following can be used to transmit CW in the amateur bands?

Straight Key

Electronic Keyer

Computer Keyboard

“All of these choices are correct”

What is a "parity" bit?

An extra code element used to detect errors in received data

**T9A – Antennas; vertical and horizontal, concept of gain, common portable and mobile antennas, relationships between antenna length and frequency**

What is a beam antenna?

An antenna that concentrates signals in one direction

Which of the following is true regarding vertical antennas?

The electric field is perpendicular to the Earth

Which of the following describes a simple dipole mounted so the conductor is parallel to the Earth's surface?

A horizontally polarized antenna

What is a disadvantage of the "rubber duck" antenna supplied with most handheld radio transceivers?

It does not transmit or receive as effectively as a full-sized antenna

How would you change a dipole antenna to make it resonant on a higher frequency?

Shorten it

What type of antennas are the quad, Yagi, and dish?

Directional antennas

What is a good reason not to use a "rubber duck" antenna inside your car?

Signals can be significantly weaker than when it is outside of the vehicle

What is the approximate length, in inches, of a quarter-wavelength vertical antenna for 146 MHz?

19

What is the approximate length, in inches, of a 6 meter 1/2-wavelength wire dipole antenna?

112

In which direction is the radiation strongest from a half-wave dipole antenna in free space?

Broadside to the antenna

What is meant by the gain of an antenna?

The increase in signal strength in a specified direction when compared to a reference antenna

**T9B - Feedlines; types, losses vs. frequency, SWR concepts, matching weather protection, connectors**

Why is it important to have a low SWR in an antenna system that uses coaxial cable feedline?  
To allow the efficient transfer of power and reduce losses

What is the impedance of the most commonly used coaxial cable in typical amateur radio installations?  
50 ohms

Why is coaxial cable used more often than any other feedline for amateur radio antenna systems?  
It is easy to use and requires few special installation considerations

What does an antenna tuner do?  
It matches the antenna system impedance to the transceiver's output impedance

What generally happens as the frequency of a signal passing through coaxial cable is increased?  
The loss increases

Which of the following connectors is most suitable for frequencies above 400 MHz?  
A Type N connector

Which of the following is true of PL-259 type coax connectors?  
They are commonly used at HF frequencies

Why should coax connectors exposed to the weather be sealed against water intrusion?  
To prevent an increase in feedline loss

What might cause erratic changes in SWR readings?  
A loose connection in an antenna or a feedline

What electrical difference exists between the smaller RG-58 and larger RG-8 coaxial cables?  
RG-8 cable has less loss at a given frequency

Which of the following types of feedline has the lowest loss at VHF and UHF?  
Air-insulated hard line

**T0A – AC power circuits; hazardous voltages, fuses and circuit breakers, grounding, lightning protection, battery safety, electrical code compliance**

Which is a commonly accepted value for the lowest voltage that can cause a dangerous electric shock?

30 volts

How does current flowing through the body cause a health hazard?

By heating tissue

It disrupts the electrical functions of cells

It causes involuntary muscle contractions

“All of these choices are correct”

What is connected to the green wire in a three-wire electrical AC plug?

Safety ground

What is the purpose of a fuse in an electrical circuit?

To interrupt power in case of overload

Why is it unwise to install a 20-ampere fuse in the place of a 5-ampere fuse?

Excessive current could cause a fire

What is a good way to guard against electrical shock at your station?

Use three-wire cords and plugs for all AC powered equipment

Connect all AC powered station equipment to a common safety ground

Use a circuit protected by a ground-fault interrupter

“All of these choices are correct”

Which of these precautions should be taken when installing devices for lightning protection in a coaxial cable feedline?

Ground all of the protectors to a common plate which is in turn connected to an external ground

What is one way to recharge a 12-volt lead-acid station battery if the commercial power is out?

Connect the battery to a car's battery and run the engine

What kind of hazard is presented by a conventional 12-volt storage battery?

Explosive gas can collect if not properly vented

What can happen if a lead-acid storage battery is charged or discharged too quickly?

The battery could overheat and give off flammable gas or explode

Which of the following is good practice when installing ground wires on a tower for lightning protection?

Ensure that connections are short and direct

What kind of hazard might exist in a power supply when it is turned off and disconnected?

You might receive an electric shock from stored charge in large capacitors

What safety equipment should always be included in home-built equipment that is powered from 120V AC power circuits?

A fuse or circuit breaker in series with the AC "hot" conductor

## HamElmer.com Technician Q&A Format

### **T0B – Antenna installation; tower safety, overhead power lines**

When should members of a tower work team wear a hard hat and safety glasses?

At all times when any work is being done on the tower

What is a good precaution to observe before climbing an antenna tower?

Put on a climbing harness and safety glasses

Under what circumstances is it safe to climb a tower without a helper or observer?

Never

Which of the following is an important safety precaution to observe when putting up an antenna tower?

Look for and stay clear of any overhead electrical wires

What is the purpose of a gin pole?

To lift tower sections or antennas

What is the minimum safe distance from a power line to allow when installing an antenna?

So that if the antenna falls unexpectedly, no part of it can come closer than 10 feet to the power wires

Which of the following is an important safety rule to remember when using a crank-up tower?

This type of tower must never be climbed unless it is in the fully retracted position

What is considered to be a proper grounding method for a tower?

Separate eight-foot long ground rods for each tower leg, bonded to the tower and each other

Why should you avoid attaching an antenna to a utility pole?

The antenna could contact high-voltage power wires

Which of the following is true concerning grounding conductors used for lightning protection?

Sharp bends must be avoided

Which of the following establishes grounding requirements for an amateur radio tower or antenna?

Local electrical codes

**T0C - RF hazards; radiation exposure, proximity to antennas, recognized safe power levels, exposure to others**

What type of radiation are VHF and UHF radio signals?

Non-ionizing radiation

Which of the following frequencies has the lowest Maximum Permissible Exposure limit?

50 MHz

What is the maximum power level that an amateur radio station may use at frequencies above 30 MHz before an RF exposure evaluation is required?

50 watts PEP at the antenna

What factors affect the RF exposure of people near an amateur station antenna?

Frequency and power level of the RF field

Distance from the antenna to a person

Radiation pattern of the antenna

"All of these choices are correct"

Why do exposure limits vary with frequency?

The human body absorbs more RF energy at some frequencies than at others

Which of the following is an acceptable method to determine that your station complies with FCC RF exposure regulations?

By calculation based on FCC OET Bulletin 65

By calculation based on computer modeling

By measurement of field strength using calibrated equipment

"All of these choices are correct"

What could happen if a person accidentally touched your antenna while you were transmitting?

They might receive a painful RF burn

Which of the following actions might amateur operators take to prevent exposure to RF radiation in excess of FCC-supplied limits?

Relocate antennas

How can you make sure your station stays in compliance with RF safety regulations?

By re-evaluating the station whenever an item of equipment is changed

Why is duty cycle one of the factors used to determine safe RF radiation exposure levels?

It affects the average exposure of people to radiation

What is meant by "duty cycle" when referring to RF exposure?

The ratio of "on" time to "off" time of a transmitted signal

**Graphics for 2010 Technician Question Pool - Exam Element 2**  
**Effective July 1, 2010**

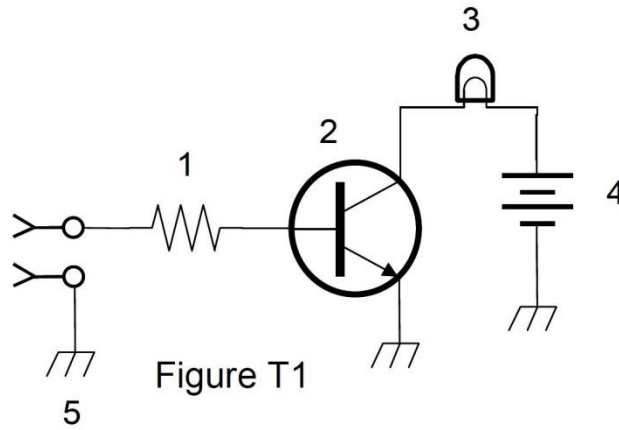

Figure T1

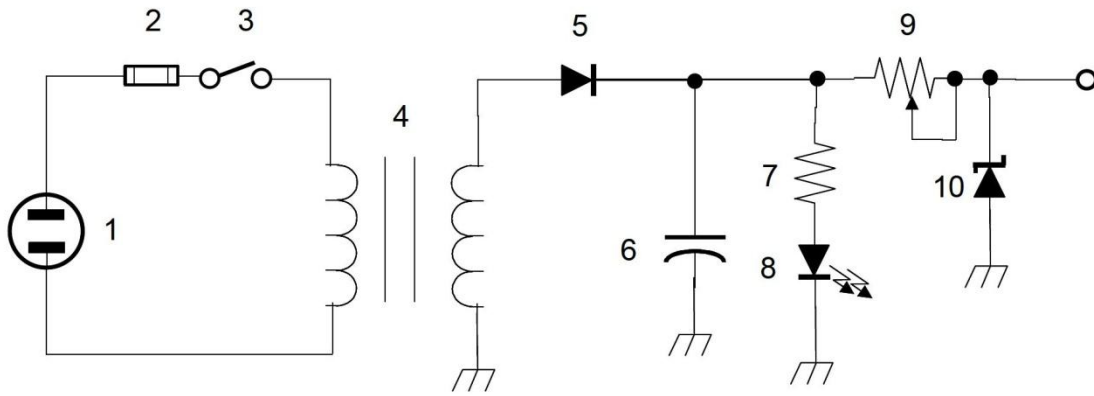

Figure T2

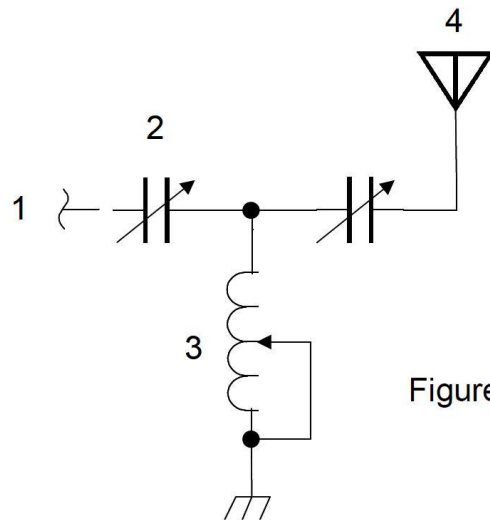

Figure T3

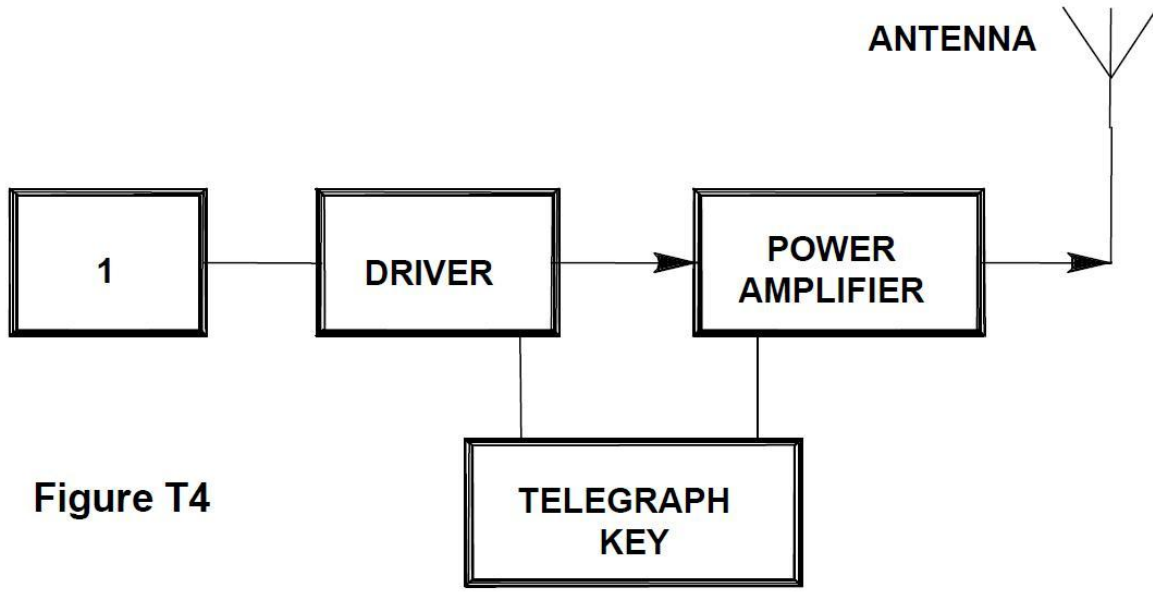

Figure T4

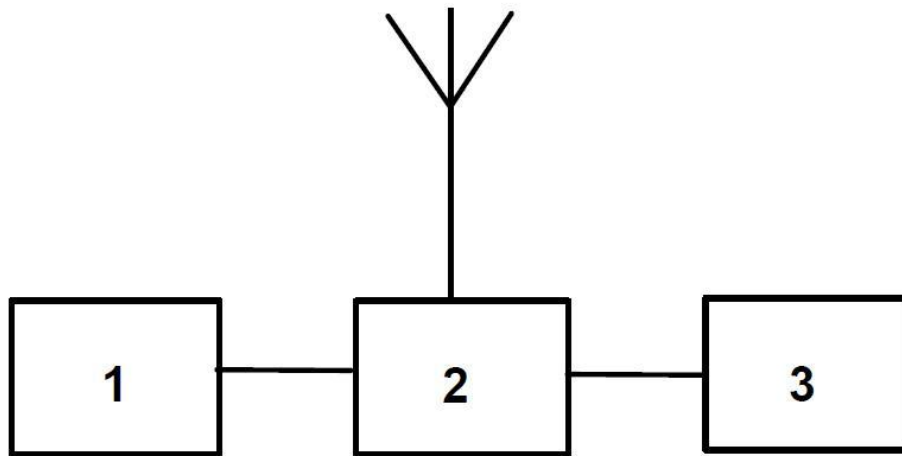

Figure T5



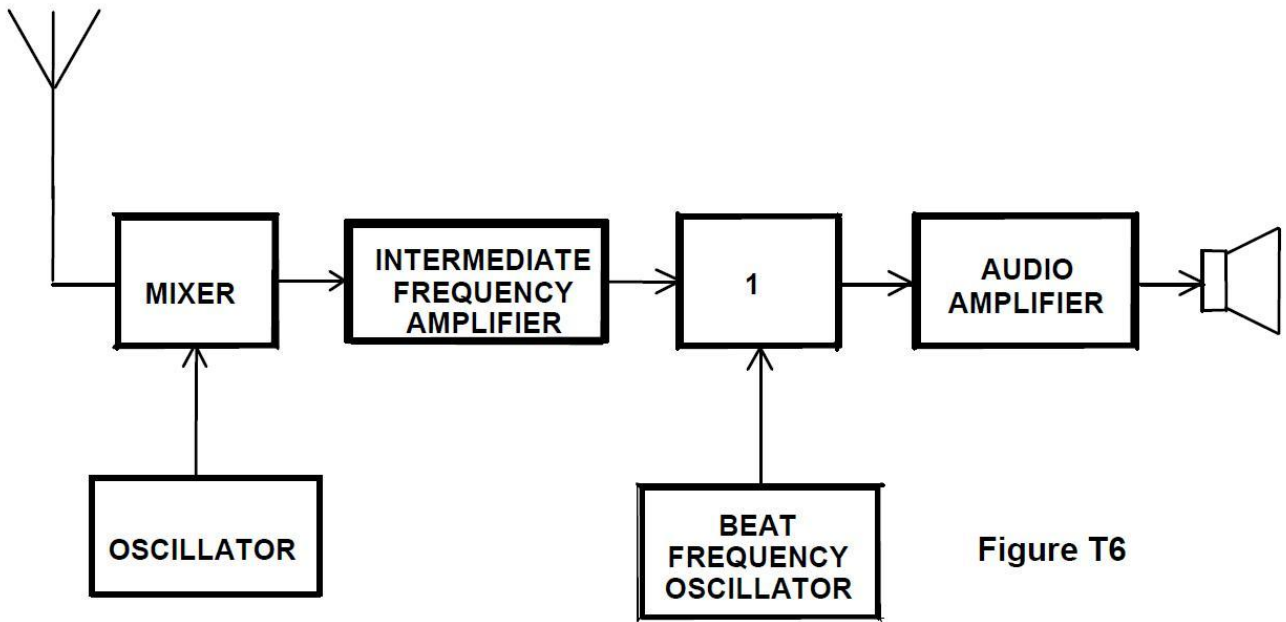

Figure T6

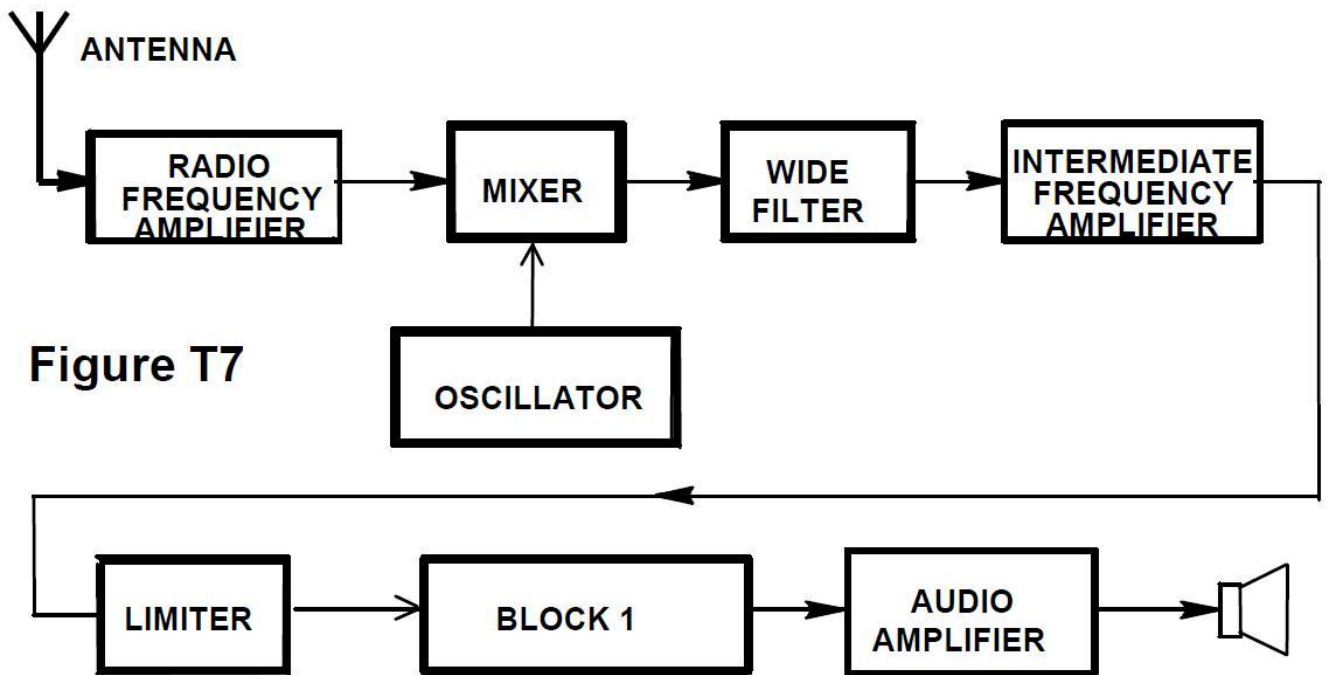

Figure T7

## Index

12 volts, 18, 20, 21  
alternating current, 14, 20, 25  
Amateur operator, 4  
Amperes, 18  
amplifier, 23, 26  
antennas, 10, 13, 31, 34, 37, 38  
ARES, 12  
bandwidth, 11, 17, 30  
Carbon-zinc, 22  
check, 12, 33  
coaxial cable, 25, 28, 35, 36  
compensation, 7  
Contesting, 32  
control commands, 7  
Control operator, 8  
Copper, 18  
CQ, 10  
crank-up tower, 37  
CTCSS, 11  
Current, 18, 21  
CW, 5, 9, 13, 17, 26, 30, 33  
DC, 20, 22  
direct current, 18, 25  
dish, 34  
dummy load, 28  
electrical circuit, 22, 24, 36  
Emergency, 12  
EMF, 18  
Extra, 9  
fast-scan TV transmission, 30  
ferrite chokes, 27  
flow of electrons, 18  
FM, 10, 11, 26, 27, 30, 31  
Frequency, 4, 14, 38  
fuse, 36  
gateway, 32  
Glass, 18  
grace period, 6  
green wire, 36  
grid locator, 32  
ground rods, 37  
ground-fault interrupter, 36  
hard hat, 37  
Hertz, 20  
high-pass filters, 27  
image, 33  
Interference, 27  
International Space Station, 31  
ionosphere, 13, 15  
IRLP, 32  
ITU, 5, 7  
keypad, 17, 32  
kilovolt, 19  
LEO, 31  
lightning, 36, 37  
Low Earth Orbit, 31  
memory, 17  
microphone, 16, 17, 27  
microvolt, 19  
milliamperes, 19  
milliwatts, 19  
Moisture contamination, 28  
net control station, 12  
NTSC, 33  
offset, 10, 11, 17  
overhead electrical wires, 37  
Part 15, 27  
Part 97, 4, 12  
Phase Shift Keying, 33  
Picket fencing, 13  
PL, 35  
polarization, 13  
Power, 18, 20  
primary users, 5  
Propagation, 15  
PSK, 33  
PSK31, 33  
QRM, 11  
QSY, 11  
quad, 34  
RACES, 12  
Radio Amateur Civil Emergency Service, 12  
radio control craft, 7  
Radio direction finding, 32  
radio horizon, 15  
receiver, 11, 16, 17, 26, 27, 33  
Receiver Incremental Tuning, 17  
repeater station, 4  
resistance, 21, 29  
Resistance, 21, 22  
resistor, 21, 24  
restricted sub-bands, 5  
RF exposure evaluation, 38  
RF filter, 27  
RIT, 17  
safety glasses, 37  
Simplex, 11  
Single sideband, 30  
speaker, 16  
special event station, 32  
speed of light, 14  
splatter, 11  
sporadic E, 15  
spurious emissions, 11  
squelch, 11, 17  
SSB, 11, 13, 17, 26, 30  
Station identification, 9, 10  
SWR, 28, 35  
telecommand, 4, 32  
telephone, 27  
ten minutes, 9, 10  
transceiver, 16, 17, 18, 26, 27, 32, 35  
transmitter, 5, 10, 11, 16, 17, 26, 27, 28, 31, 32  
TV, 16, 27, 33  
ultraviolet, 28  
Upper sideband, 30  
vanity call sign, 6  
vertical antenna, 34  
VFO, 17  
VHF/UHF, 11  
VoIP, 32  
wattmeter, 28  
Wavelength, 14  
Yagi, 34